

# Type 581, Manually operated

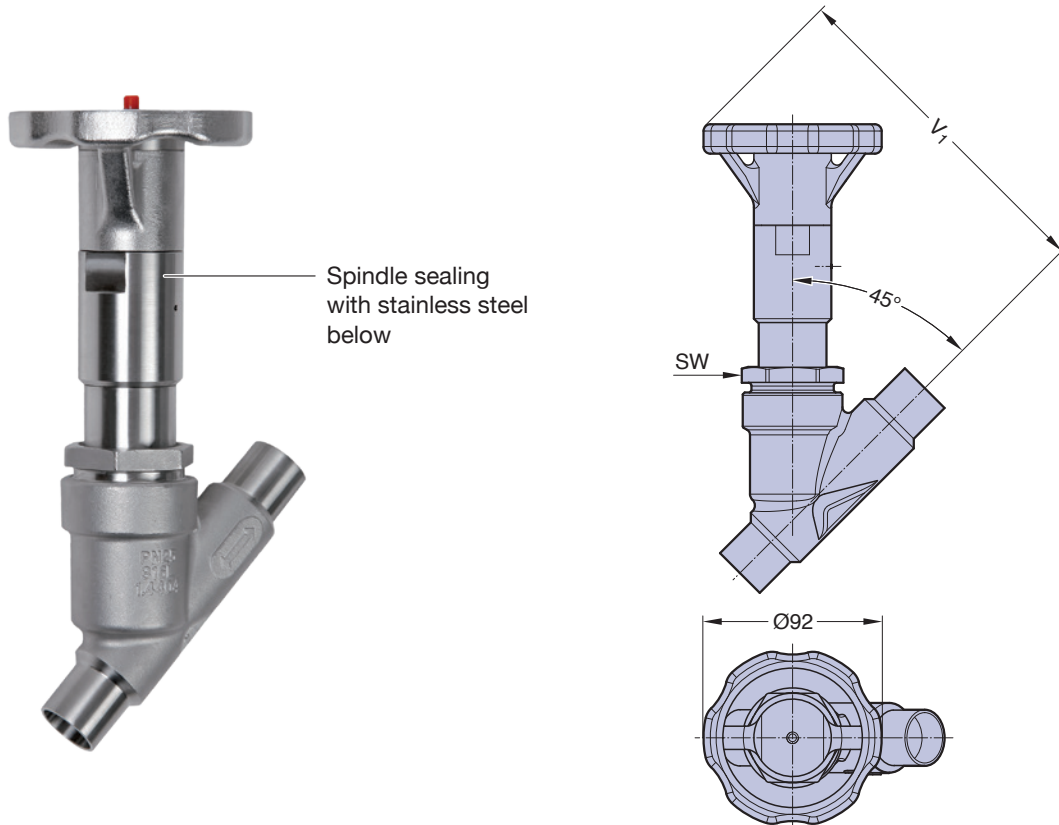

## Advantages:

- Hygienic design, easy cleaning
- High temperature resistance
- Stainless steel below
- Minimized dead leg design
- Optical position indicator
- Easy maintenance
- Good regulation properties
- Clean and smooth exterior for sterile washdowns
- Regulating cone

## Specific application:

- Pure or clean steam and gaseous media

Measurement and weight table

DN	SW	V <sub>1</sub>	Total weight ca. (kg)
15	36	177	1,8
20	41	168	1,9
25	46	175	2,1
32	55	183	2,9
40	60	189	3,4
50	75	197	4,4

Valve body types see page 115 - 117

Control equipment and accessories see page 132 - 139

Working pressure, see table page 101.  
All pressures are gauge pressures.

Ordering key see page 118 and 119.