

## T 3964 EN Type 3964 Solenoid Pilot Valve

### Application

Solenoid pilot valves for controlling Type 3756 Booster Valves, Type 3965 and Type 3968 Solenoid Valve Islands as well as valves according to ISO 5599-1 with CNOMO interface

The Type 3964 Solenoid Pilot Valves provide a high level of operational reliability for controlling Type 3756 Booster Valves, Type 3965 and Type 3968 Solenoid Valve Islands as well as valves according to ISO 5599-1 with CNOMO interface.

Intrinsically safe, low-power binary signals issued by automation equipment or fieldbus systems can be used for controlling purposes.

### Special features

- SIL according to IEC 61508
- Electropneumatic binary converter with flapper/nozzle assembly
- Nominal signals 6, 12 or 24 V DC
- Intrinsically safe version II 2G Ex ia IIC T6 Gb, II 3G Ex nA II T6 Gc, CSA and FM
- 6 to 27 mW (DC) power consumption
- Reverse polarity protection
- Manual override using pushbutton or pushbutton/switch (optional)
- Connector according to DIN EN 175301-803, type C
- Corrosion-resistant enclosure with degree of protection IP 54
- Supply air 1.4 to 3.6 bar
- Connection for direct mounting or CNOMO adapter
- Connecting plates, holding two or four valves, for a 35 mm top-hat rail for controlling pneumatic components with threaded connection (see Accessories)
- Ambient temperature from  $-45$  to  $+80$  °C



**Fig. 1:** Solenoid pilot valve with flanges

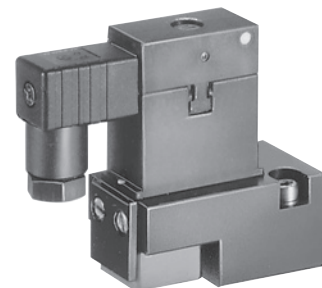

**Fig. 2:** Solenoid pilot valve with CNOMO adapter plate

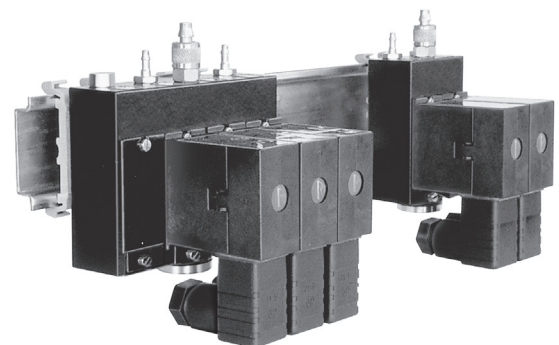

**Fig. 3:** Solenoid pilot valves with connecting plates, holding two or four valves, mounted on a 35 mm top-hat rail according to EN 50022

## Principle of operation

The Type 3964 Solenoid Pilot Valves consist of an electropneumatic binary converter (A) and a manual override (B, optional). A diaphragm switching element (C, optional) is used to amplify the output signal to twice the flow rate (see Fig. 4).

In the idle position, the flapper (2) is lifted off the outlet nozzle (1) by the spring (3). As a result, a pressure lower than the deactivation pressure of the diaphragm switching element (C) builds up in the pressure divider, which consists of the restrictor (5) and outlet nozzle (1).

When the solenoid coil (4) is energized by an electric binary signal, the outlet nozzle (1) is closed by the flapper (2) against the force of the spring (3). This causes the pressure in the pressure divider to rise above the switch-on pressure of the diaphragm switching element (C), switching it to the operating position. After the solenoid coil is de-energized, the diaphragm switching element (C) is switched to the idle position again by a return spring.

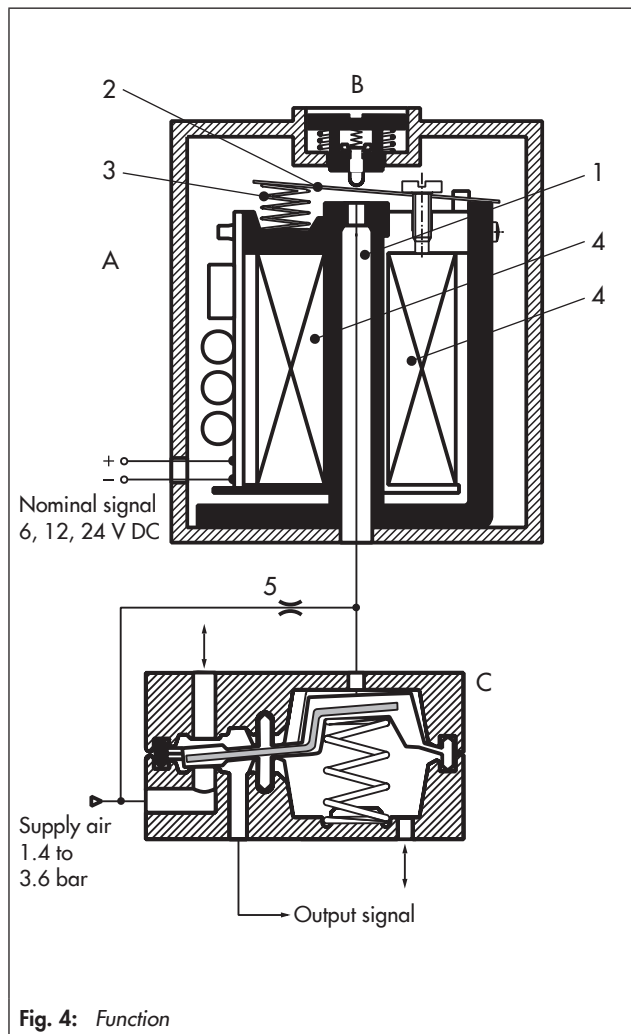
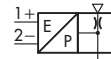
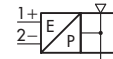

Fig. 4: Function



**Type 3964-XXX000X000XX**  
with connection for direct  
mounting (without restrictor)



**Type 3964-XXX100X000XX**  
with CNOMO adapter plate  
(without restrictor)

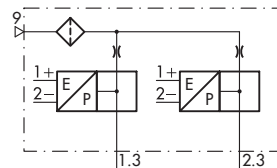

Connecting plate to hold two valves  
(including restrictors)

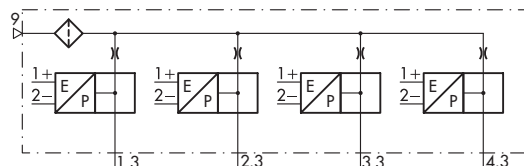

Connecting plate to hold four valves  
(including restrictors)

Fig. 5: Logic symbols

## Technical data

General data		
Design	Solenoid with flapper/nozzle assembly	
Degree of protection	IP 20/IP 54 (without/with mounted cable socket)	
Material	Enclosure	Polyamide PA6-3-T, black
	Adapter plate	Black anodized aluminum
	Screws	1.4571
	Springs	1.4310
	Seals	Silicone rubber, Perbunan
Ambient temperature	See Electrical data and Pneumatic data	
Mounting position	Any (see mounting and operating instructions ► EB 3964)	
Weight, approx.	50 g 100 g with CNOMO adapter plate	

Electric data					
Type 3964		-X1	-X2	-X3	
Nominal signal	$U_N$	6 V DC; max. 27 V <sup>1)</sup>	12 V DC; max. 25 V <sup>1)</sup>	24 V DC; max. 32 V <sup>1)</sup>	
ON switching point	$U_{+80\text{ °C}}$	$\geq 4.8\text{ V}$	$\geq 9.6\text{ V}$	$\geq 18\text{ V}$	
	$I_{+20\text{ °C}}$	$\geq 1.41\text{ mA}$	$\geq 1.52\text{ mA}$	$\geq 1.57\text{ mA}$	
	$P_{+20\text{ °C}}$	$\geq 5.47\text{ mW}$	$\geq 13.05\text{ mW}$	$\geq 26.71\text{ mW}$	
OFF switching point	$U_{-25\text{ °C}}$	$\leq 1.0\text{ V}$	$\leq 2.4\text{ V}$	$\leq 4.7\text{ V}$	
Impedance	$R_{+20\text{ °C}}$	2.6 k $\Omega$	5.5 k $\Omega$	10.7 k $\Omega$	
Temperature influence		0.4 %/°C	0.2 %/°C	0.1 %/°C	
Type of protection Ex ia IIC <sup>2)</sup> for use in hazardous areas (Zone 1)					
Type 3964		-11	-12	-13	
Maximum values when connected to a certified intrinsically safe circuit					
Output voltage	$U_i$	Pairs of values $U_i/I_i$ for nominal signals 6, 12, 24 V DC: 25 V/150 mA, 27 V/125 mA, 28 V/115 mA, 30 V/100 mA, 32 V/85 mA			
Output current	$I_i$				
Outer capacitance	$C_i$	$\approx 0$			
Outer inductivity	$L_i$	$\approx 0$			
Ambient temperature in temperature class					
	T6	-20 to +60 °C			
	T5	-20 to +70 °C			
	T4	-20 to +80 °C			
Type of protection Ex nA II <sup>3)</sup> for use in hazardous areas (Zone 2)					
Type 3964		-81	-82	-83	
Ambient temperature in temperature class					
	T6	-45 to +60 °C			
	T5	-45 to +70 °C			
	T4	-45 to +80 °C			
Switching time		$\leq 15\text{ ms}$			
Temperature influence		0.4 %/°C	0.2 %/°C	0.12 %/°C	
Connection	Connector type C according to DIN EN 175301-803, with cable socket <sup>4)</sup> , distance between contacts 8 mm, 9.4 mm special connector for PCB in Type 3965 Solenoid Valve Island, without cable socket <sup>5)</sup>				

<sup>1)</sup> Maximum permissible value at 100 % duty cycle. The maximum permissible value  $U_i$  applies to explosion-protected versions.

<sup>2)</sup> Type of protection II 2 G Ex ia IIC T6 (Zone 1) according to EC Type Examination Certificate PTB 98 ATEX 2047

<sup>3)</sup> Type of protection II 3 G Ex nA II T6 (Zone 2) according to Statement of Conformity PTB 01 ATEX 2193 X

<sup>4)</sup> The cable socket with gasket is included in the scope of delivery.

<sup>5)</sup> The cable socket with gasket can be included in the scope of delivery as an option (see Versions and order specifications).

Pneumatic data		
Supply air	Medium	Instrument air, free from corrosive substances
	Pressure	1.4 to 3.6 bar
Temperature influence		$\geq 1.2$ bar at 1.4 bar supply air $\geq 1.8$ bar at 2.0 bar supply air $\geq 2.5$ bar at 3.6 bar supply air
Air consumption		$\leq 60$ l/h at 1.4 bar supply air in neutral position $\leq 15$ l/h at 1.4 bar supply air in operating position
$K_{VS}^{1)}$		0.01
Ambient temperature <sup>2)</sup>		-25 to +80 °C -45 to +80 °C
Connection	Connection for direct mounting, optionally with CNOMO adapter plate or connecting plate	

1) The air flow rate when  $p_1 = 2.4$  bar and  $p_2 = 1.0$  bar is calculated using the following formula:

$$Q = K_{VS} \times 36.22 \text{ in m}^3/\text{h.}$$

2) The maximum permissible ambient temperature of the solenoid pilot valve depends on type of protection and temperature class.

## Dimensions in mm

### Dimensions of solenoid pilot valves with connection for direct mounting

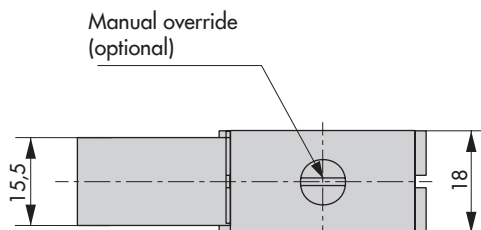
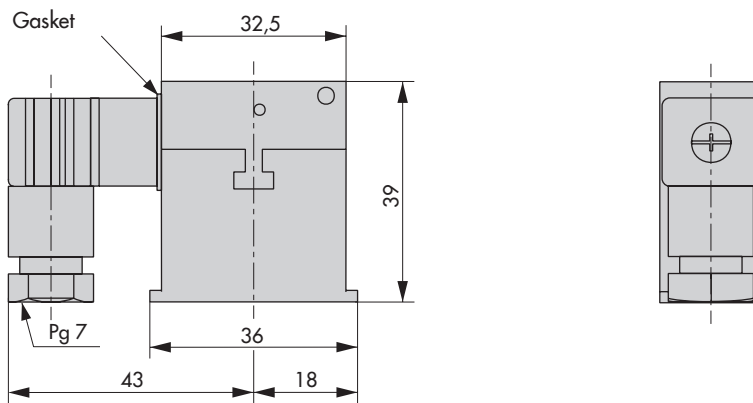
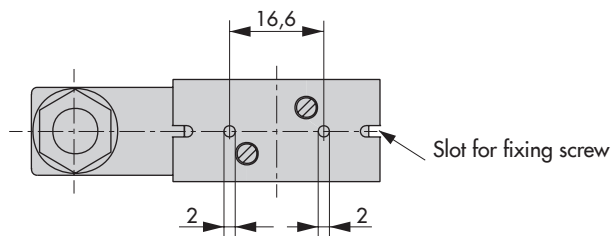

**Dimensions of solenoid pilot valves with CNOMO adapter plate**

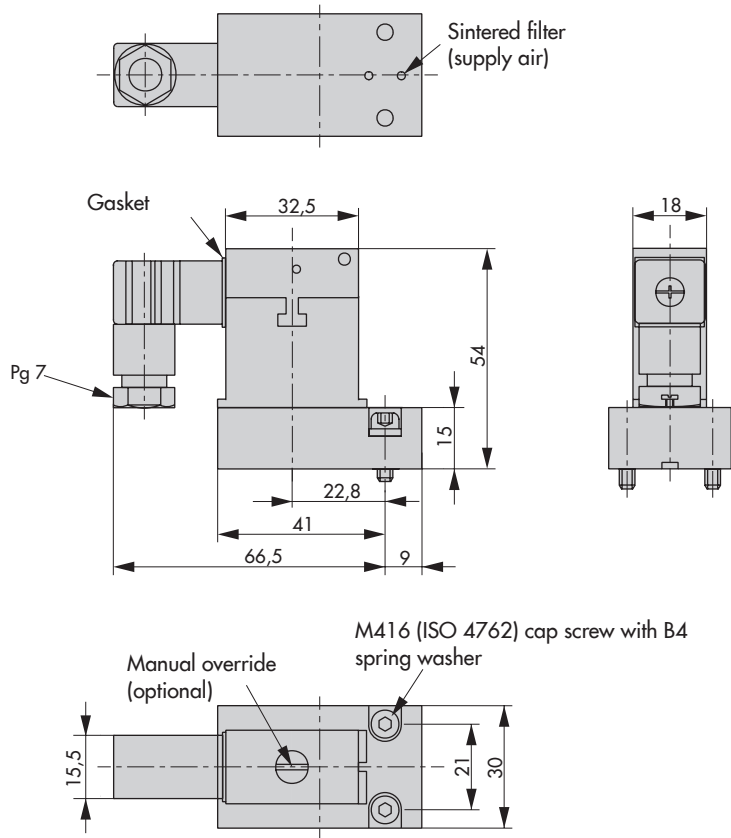

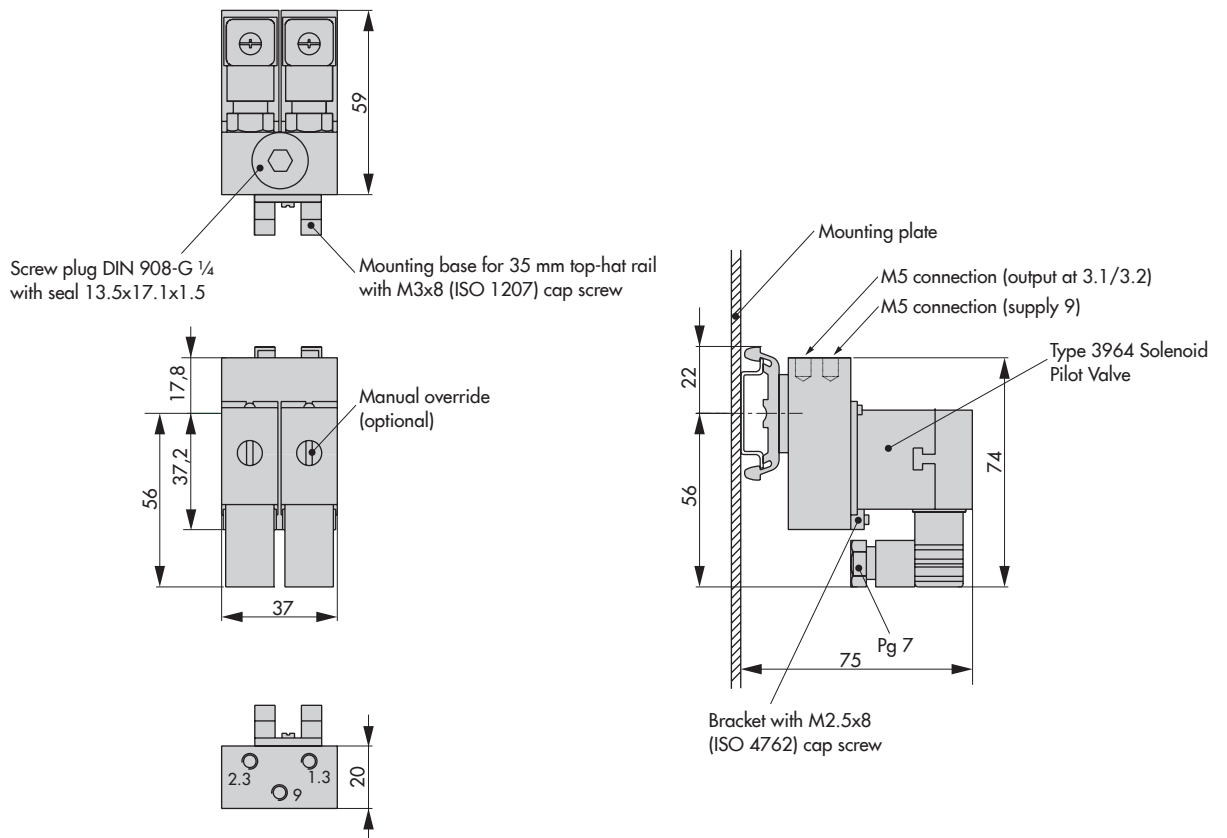

**Dimensions of solenoid pilot valves with connecting plate to hold two valves**

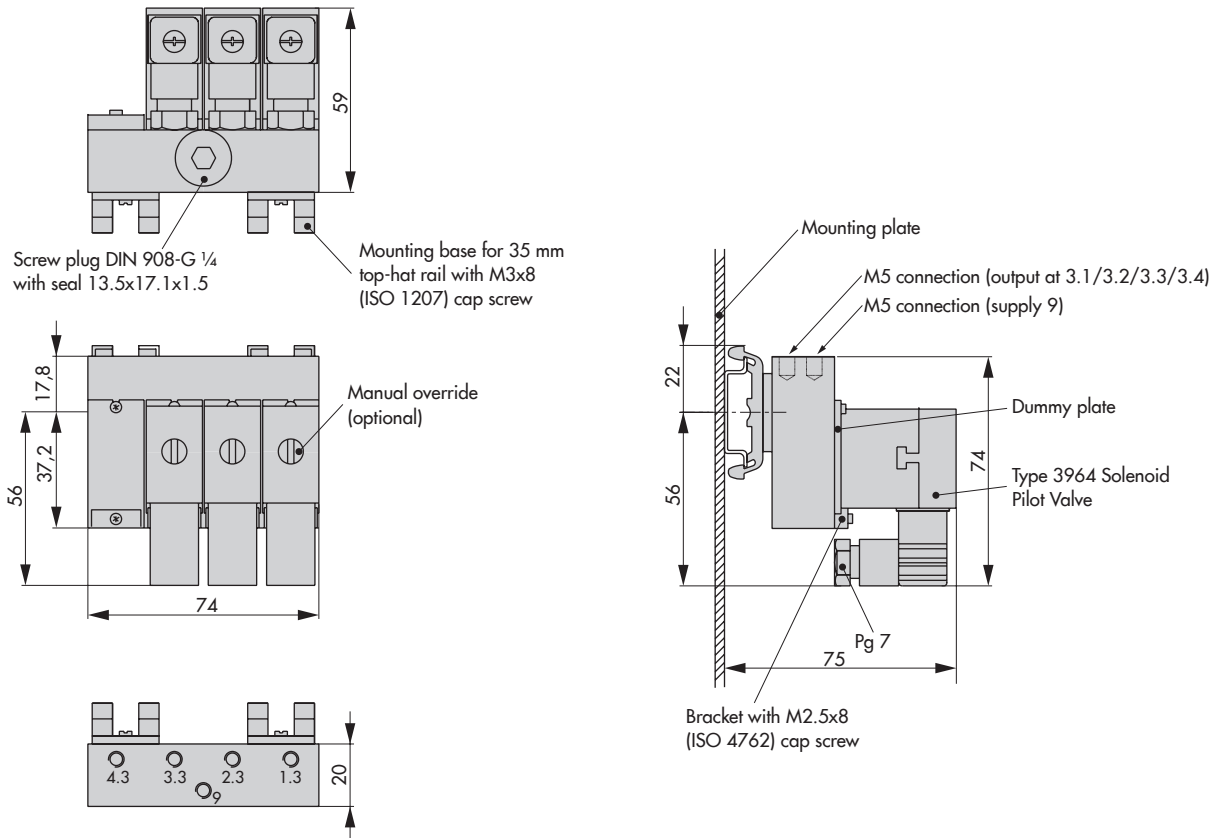

**Dimensions of solenoid pilot valves with connecting plate to hold four valves**



**Summary of explosion protection approvals**

Type	Certification			Type of protection
3964-1	 EC type examination certificate	Number	PTB 98 ATEX 2047	II 2G Ex ia IIC T6 Gb
		Date	2016-01-29	
3964-3	CSA	Number	1607848	Ex ia IIC T6: Class I, Zone 0; Class I, Division 1, Groups A, B, C and D; Class II, Division 1, Groups E, F and G; Class III; Type 3 Enclosure
		Date	2005-09-16	
	FM	Number	3020228	
		Date	2015-10-12	
3964-8	 Statement of conformity	Number	PTB 01 ATEX 2193 X	II 3G Ex nA II T6 Gc
		Date	2016-03-02	

**Article code**

Solenoid pilot valve	Type 3964-	x	x	x	x	x	x	x	x	x	x	x	x	x	x
Type of protection															
No explosion protection	0														
II 2G Ex ia IIC T6 Gb (ATEX) <sup>1)</sup>	1														
Ex ia IIC (CSA) und AEx ia IIC (FM)	3														
II 3G Ex nA II T6 Gc (ATEX) <sup>2)</sup>	8														
Nominal signal															
6 V DC, 5.47 mW power consumption	1														
12 V DC, 13.05 mW power consumption	2														
24 V DC, 26.71 mW power consumption	3														
Manual override															
Without manual override (SIL)		0													
Pushbutton		1													
Pushbutton/switch		2													
Mounting															
Interface for direct mounting of Type 3964				0											
CNOMO adapter plate, 30 mm				1											
K <sub>VS</sub> <sup>3)</sup>															
0.01					0										
Pressure reducer															
Without air pressure reducing station						0									
Electrical connection															
9.4 mm special connector for PCB in Type 3965 Solenoid Valve Island, without cable socket <sup>4)</sup>								1							
Connector type C according to DIN EN 175301-803, with cable socket <sup>5)</sup> , distance between contacts 8 mm								3							
Degree of protection															
IP 54									0						
Supply air															
1.4 to 3.6 bar										0					
Indicator															
Without indicator											0				
Ambient temperature <sup>6)</sup>															
-25 to +80 °C													1		
-45 to +80 °C													2		
Safety function															
Without safety function															0
SIL <sup>7)</sup>															1

<sup>1)</sup> EC type examination certificate PTB 98 ATEX 2047

<sup>2)</sup> Statement of conformity PTB 01 ATEX 2193 X

<sup>3)</sup> The air flow rate when  $p_1 = 2.4$  bar and  $p_2 = 1.0$  bar is calculated using the following formula:  $Q = K_{VS} \times 36.22$  in m<sup>3</sup>/h.

<sup>4)</sup> The cable socket with gasket is not included in the scope of delivery (see Accessories).

<sup>5)</sup> The cable socket with gasket is included in the scope of delivery.

<sup>6)</sup> The maximum permissible ambient temperature of the solenoid pilot valve depends on type of protection and temperature class.

<sup>7)</sup> SIL according to IEC 61508

## Accessories

- Cable socket, 9,4 mm special connector of black polyamide, type C, distance between contacts 9.4 mm, cable gland Pg 7 (for 3.5 to 6 mm cable diameter)  
**Order no. 8831-0533**
- Cable socket according to DIN EN 175301-803, made of black polyamide, type C, distance between contacts 8 mm, cable gland Pg 7 (for 3.5 to 6 mm cable diameter)  
**Order no. 8831-0535**
- ECO gasket, free of silicone (for cable socket, 9.4 mm special connector)  
**Order no. 8831-0545**
- ECO gasket, free of silicone (for cable socket according to DIN EN 175301-803, type C, distance between contacts 8 mm)  
**Order no. 8831-0546**
- Connecting plate, **designed for two valves**, made of anodized black aluminum, M5 connections, **without** indicators, including two holders with M2.5x8 (ISO 4762) cap screw  
**Order no. 1890-5789**
- Connecting plate, **designed for four valves**, made of anodized black aluminum, M5 connections, **without** indicators, including four holders with M2.5x8 (ISO 4762) cap screw  
**Order no. 1890-5790**
- Connecting plate, **designed for two valves**, made of anodized black aluminum, M5 connections, **with** two indicators, including two holders with M2.5x8 (ISO 4762) cap screw  
**Order no. 1890-5791**
- Connecting plate, **designed for four valves**, made of anodized black aluminum, M5 connections, **with** four indicators, including four holders with M2.5x8 (ISO 4762) cap screw  
**Order no. 1890-5792**
- Mounting base for 35 mm top-hat rail according to EN 50022 with M3x8 (ISO 1207) cap screw (two pieces required for connecting plate holding four valves)  
**Order no. 1400-5931**
- Dummy plate with M5x6 (ISO 1207) screw plug and M5 gasket (used to blank off unused stations)  
**Order no. 1400-7588**

## Spare parts

- Bracket with M2.5x8 (ISO 4762) cap screw (to attach a solenoid pilot valve to the connecting plate)  
**Order no. 1400-7587**
- O-ring 2.9x1.78 made of nitrile butadiene rubber (for CNOMO interface)  
**Order no. 8421-0044**
- Restrictor  
**Order no. 1690-9995**
- O-ring 2x1 made of silicone rubber (for restrictor)  
**Order no. 8421-0012**