

T 3015 EN

Type 42-36 Flow Regulator

Series 42 Self-operated Regulators



Application

Flow rate control in district heating systems or large heating networks. · Valves DN 15 to 250 ¹⁾ · Pressure rating PN 16 to 40
Suitable for liquids, gases and vapors from 5 to 150 °C ¹⁾

The valve **closes** when the flow rate **rises**.

The flow regulator is used to limit the flow rate in the pipeline.
The set point for the flow rate is adjusted at the restriction.

Special features

- Low-noise, medium-controlled proportional regulator requiring little maintenance
- Valve size DN 125 to 250 with fixed plug guide as standard, e.g. installation in riser pipes.
- Suitable for circuit water, water/glycol mixtures, steam and air as well as other liquids, gases and vapors, provided these do not affect the characteristics of the operating diaphragm.
- Single-seated valve with a plug balanced by a stainless steel bellows or a balancing diaphragm.
- Valve body optionally available in cast iron, spheroidal graphite iron, cast steel, cast stainless steel or forged stainless steel.

Versions

Type 42-36 (Fig. 1) · Regulators for valve sizes DN 15 to 250 ¹⁾ · Type 2423 Valve with integrated restriction for adjusting the flow rate set point · Type 2426 Actuator with high-pressure control line · Flange connections · Balancing bellows made of CrNiMo steel or balancing diaphragm made of EPDM (DN 65 to 250)

The set point ranges for the flow rate based on water listed in Table 2 apply to a differential pressure at the restriction of either 0.2 or 0.5 bar.

Special version

- With internal parts made of FKM, e.g. for use with mineral oils
- Liquids and vapors up to 220 °C
- ANSI/JIS version

¹⁾ On request: valves larger than DN 250 for steam and gases
Other temperature ranges

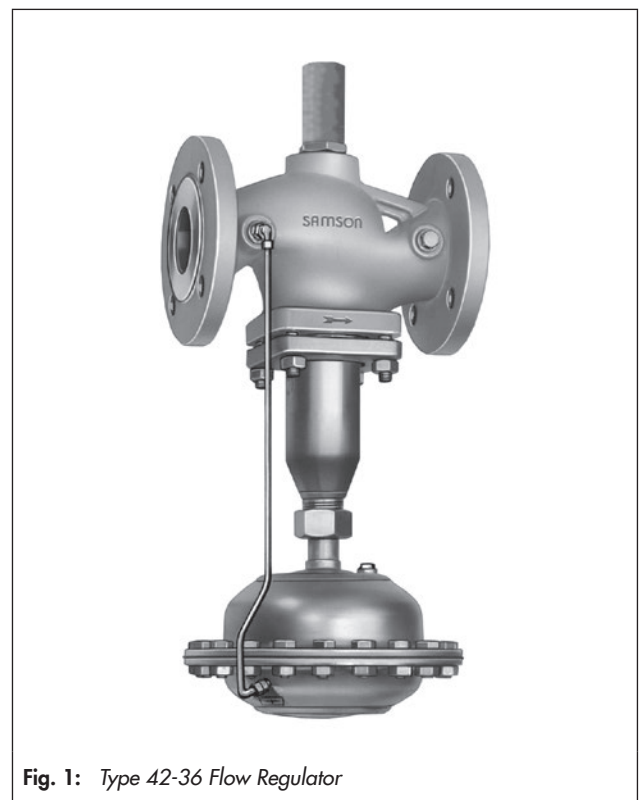

Fig. 1: Type 42-36 Flow Regulator

Accessories

Required accessories, such as compression-type fittings, needle valves, equalizing tanks and control lines, are listed in Data Sheet ► T 3095.

Principle of operation

The medium flows through the valve in the direction indicated by the arrow. The flow rate is determined by the free area between the restriction (1.4) adjusted at the set point adjuster (1.1) and the valve plug (3).

No flow forces act on the plug of a fully balanced valve.

Regulators balanced by a bellows or a diaphragm only differ in the pressure balancing principle applied. Valves balanced by a bellows have a balancing bellows (5), whereas the valves balanced by a diaphragm (DN 65 to 250) have a balancing diaphragm (5.1). The pressure directly downstream of the restriction acts on the outside of the metal bellows or balancing diaphragm. In both cases, the forces created by the upstream and downstream pressures that act on the valve plug are balanced out.

The differential pressure created at the restriction $\Delta p_{\text{restriction}}$ operates the actuator. The pressure upstream of the restriction is transmitted through the control line (18) to the lower diaphragm chamber. The pressure downstream of the restriction passes through the hollow plug stem (7) to the diaphragm stem (6) and into the top diaphragm chamber.

If the flow rate increases, the differential pressure ($\Delta p_{\text{restriction}}$) increases at the restriction and also at the operating diaphragm (12). This additional force causes the set point springs (14) to be pressed together until the forces are balanced out again. The plug starts to close. The cross-section of flow is reduced and the flow rate drops until it reaches the adjusted set point.

Type 42-36 Differential Pressure Regulator with two diaphragms for increased functional safety (see Fig. 2)

An actuator with two diaphragms is always required when an FKM diaphragm is to be used. It is especially suitable for applications with thin oils (e.g. heat transfer oil).

The two diaphragms separate both diaphragm chambers connected to the high-pressure and low-pressure connections. They generate a positioning force from the differential pressure. A mechanical diaphragm rupture indicator (22) is located between the two diaphragms. In the event of a diaphragm rupture, the pressure in the space between the two operating diaphragms starts to increase. This causes the pin in the diaphragm rupture indicator to be pushed outwards and a red ring appears, indicating the diaphragm rupture (response pressure approx. 1.5 bar). The intact operating diaphragm takes on the control task of the ruptured diaphragm.

A pressure switch can be optionally mounted to the actuator to trigger an alarm.

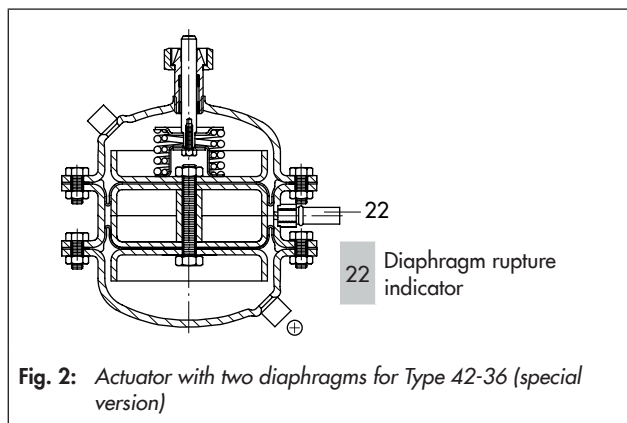
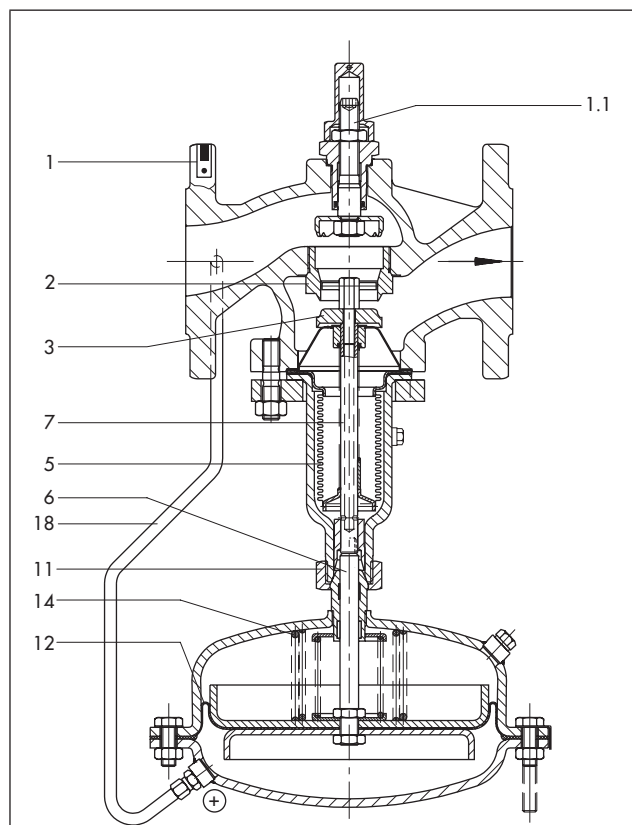
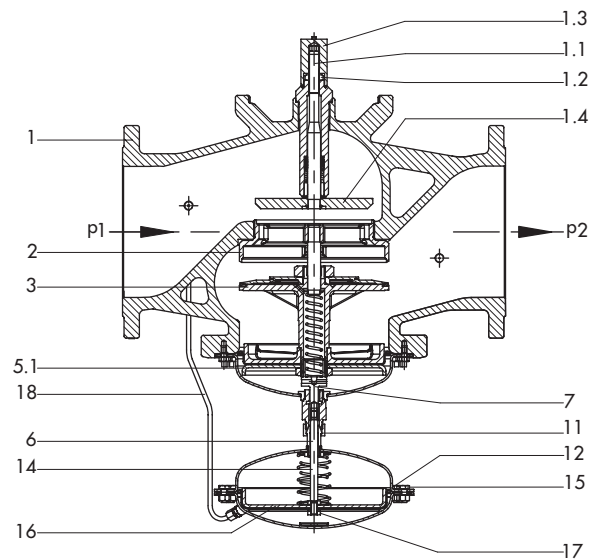

Fig. 2: Actuator with two diaphragms for Type 42-36 (special version)



Type 42-36 balanced by a bellows



Type 42-36 balanced by a diaphragm

| | | | |
|-----|---|-----|---------------------|
| 1 | Type 2423 Valve (balanced by a bellows) | 5 | Balancing bellows |
| 1.1 | Set point adjuster for flow rate | 5.1 | Balancing diaphragm |
| 1.2 | Lock nut | 6 | Diaphragm stem |
| 1.3 | Cap | 7 | Plug stem |
| 1.4 | Restriction | 11 | Coupling nut |
| 2 | Seat | 12 | Operating diaphragm |
| 3 | Plug | 14 | Set point springs |
| | | 18 | Control line |

Fig. 3: Type 42-36 · Type 2423 Valve balanced by a bellows or diaphragm

Table 1: Technical data

| Type 2423 Valve · Balanced by a bellows | | | | |
|--|--|---|---------------|--------|
| Valve size | DN 15 to 100 | | DN 125 to 250 | |
| Pressure rating | PN 16, 25 or 40 | | | |
| Max. permissible temperature | Valve body | 180 °C · Special version for steam: 220 °C | | 220 °C |
| | Actuator | See pressure-temperature diagram in ► T 3000 for additional requirements | | |
| | Actuator | With compensation chamber: steam and liquids up to 220 °C · Without compensation chamber: liquids up to 150 °C, air and nitrogen up to 150 °C ¹⁾ | | |
| Set point (differential pressure at restriction) | 0.2 bar · 0.5 bar | | | |
| Leakage class according to IEC 60534-4 | ≤0.05 % of K _{VS} coefficient | | | |
| Conformity | CE EAC | | | |
| Refer to 'Dimensions' for the assignment of actuator and valve | | | | |
| Type 2423 Valve · Balanced by a diaphragm | | | | |
| Valve size | DN 65 to 250 | | | |
| Pressure rating | PN 16, 25 or 40 | | | |
| Max. permissible temperature | Valve body | See pressure-temperature diagram in ► T 3000 | | |
| | Actuator | Liquids 150 °C, air and gases 80 °C | | |
| Set point (differential pressure at restriction) | 0.2 bar · 0.5 bar | | | |
| Leakage class according to IEC 60534-4 | ≤0.05 % of K _{VS} coefficient | | | |
| Conformity | CE EAC | | | |
| Refer to 'Dimensions' for the assignment of actuator and valve | | | | |

¹⁾ Special version: valve with orifice stem seal and operating diaphragm made of FKM

Table 2: K_{VS} coefficients, x_{FZ} values, flow rate set point ranges for water and max. permissible differential pressures Δp

| Type 2423 Valve balanced by a bellows | | | | | | | | | | | | | | |
|---|---------|-----------|-------------|-------------------------|------------|-----------|-----------|-----------|-------------------------|-----------|-----------|-----------|-----------|-----------|
| Valve size DN | 15 | 20 | 25 | 32 | 40 | 50 | 65 | 80 | 100 | 125 | 150 | 200 | 250 | |
| Valve travel | 10 mm | | | | | | 16 mm | | | 22 mm | | | | |
| K _{VS} coefficient | 4 | 6.3 | 8 | 16 | 20 | 32 | 50 | 80 | 125 | 190 | 280 | 420 | 500 | |
| x _{FZ} value | 0.65 | 0.6 | 0.55 | | 0.45 | 0.4 | | 0.35 | | | 0.3 | | | |
| Flow rate set point ranges for water in m ³ /h | | | | | | | | | | | | | | |
| Differential pressure across restriction | 0.2 bar | 0.05 to 2 | 0.15 to 3 | 0.25 to 3.5 | 0.4 to 7 | 0.6 to 11 | 0.9 to 16 | 2 to 28 | 3.5 to 35 ¹⁾ | 6.5 to 63 | 11 to 80 | 18 to 120 | 20 to 180 | 26 to 220 |
| Δp _{restriction} | 0.5 bar | 0.15 to 3 | 0.25 to 4.5 | 0.4 to 5.3 | 0.6 to 9.5 | 0.9 to 16 | 2 to 24 | 3.5 to 40 | 6.5 to 55 | 11 to 90 | 18 to 120 | 20 to 180 | 26 to 260 | 30 to 300 |
| Max. perm. differential pressure Δp | 25 bar | | | | | | 20 bar | | | 16 bar | | 12 bar | | 10 bar |
| Type 2423 Valve balanced by a diaphragm | | | | | | | | | | | | | | |
| Valve size DN | 65 | 80 | 100 | 125 | 150 | 200 | 250 | | | | | | | |
| K _{VS} coefficient | 50 | 80 | 125 | 250 | 390 | 650 | 800 | | | | | | | |
| x _{FZ} value | 0.4 | | 0.35 | | | | | 0.3 | | | | | | |
| Flow rate set point ranges for water in m ³ /h | | | | | | | | | | | | | | |
| Differential pressure across the restriction | 0.2 bar | 2 to 28 | | 3.5 to 35 ¹⁾ | | 6.5 to 63 | | 11 to 120 | | 18 to 180 | | 20 to 320 | | 26 to 350 |
| Δp _{restriction} | 0.5 bar | 3.5 to 40 | | 6.5 to 55 | | 11 to 90 | | 18 to 180 | | 20 to 260 | | 26 to 450 | | 30 to 520 |
| Max. perm. diff. pressure Δp | 10 bar | | | | | | 12 bar | | | 10 bar | | | | |

¹⁾ 7 to 35 m³/h (160 cm² actuator), 7 to 40 m³/h (320 cm² actuator)

Differential pressure across the valve

The minimum required differential pressure Δp_{min} across the valve is calculated as follows:

$$\Delta p_{\min} = \Delta p_{\text{restriction}} + \left(\frac{\dot{V}}{K_{VS}} \right)^2$$

- Δp_{min} Minimum differential pressure across the valve in bar
- Δp_{restriction} Differential pressure created at the restriction for measuring the flow rate in the regulator
- Ṃ Adjusted flow rate in m³/h
- K_{VS} Valve flow coefficient in m³/h

Table 3: Materials · Material numbers according to DIN EN

| Type 2423 Valve · Balanced by a bellows | | | | | |
|---|---|---|-------------------|-----------------------------|---|
| Pressure rating | PN 16 | PN 25 | PN 16, 25 and 40 | | |
| Valve body | Cast iron EN-GJL-250 | Spheroidal graphite iron EN-GJS-400-18-LT | Cast steel 1.0619 | Cast stainless steel 1.4408 | Forged stainless steel 1.4404 ¹⁾ |
| Seat | 1.4104, 1.4006 | | | 1.4404 | |
| Plug | Up to DN 100 | 1.4104, 1.4006 ²⁾ | | 1.4404 | |
| | DN 125 to 250 | 1.4301, 1.4404 with PTFE seal | | | |
| Plug stem | 1.4301 | | | | |
| Metal bellows | 1.4571 · DN 125 and larger: 1.4404 | | | | |
| Bottom section | P265GH | | | 1.4571 | |
| Body gasket | Graphite on metal core | | | | |
| Type 2423 · Balanced by a diaphragm | | | | | |
| Pressure rating | PN 16 | PN 25 | PN 16, 25 and 40 | | |
| Valve body | Cast iron EN-GJL-250 | Spheroidal graphite iron EN-GJS-400-18-LT | Cast steel 1.0619 | Cast stainless steel 1.4408 | – |
| Valve seat | Red brass ^{3) 4)} | | | | |
| Plug (standard version) | Red brass ^{3) 5)} with EPDM soft seal, max. 150 °C or with PTFE soft seal, max. 150 °C | | | | |
| Pressure balancing | Balancing cases made of sheet steel DD11 · EPDM balancing diaphragm, max. 150 °C or NBR diaphragm, max. 80 °C | | | | |
| Type 2426 Actuator | | | | | |
| Diaphragm cases | 1.0332 | | | 1.4301 | |
| Diaphragm | EPDM with fabric reinforcement · Special version for mineral oils: (FKM with fabric reinforcement) ⁶⁾ or (FKM without fabric reinforcement) ⁸⁾ · PVMQ diaphragm ⁹⁾ for inert gases | | | | |
| Max. perm. temperature at the diaphragm | Air and gases 80 °C; liquids 80 °C ⁸⁾ · 90 °C ⁹⁾ · 120 °C · 150 °C ⁷⁾ | | | | |
| Guide bushing | DU bushing | | | PTFE | |
| Seals | EPDM/PTFE ⁶⁾ | | | | |

¹⁾ DN 15, 25, 40 and 50 only

²⁾ Optionally with soft seal with standard K_{VS} coefficients

³⁾ Special version 1.4409

⁴⁾ DN 65 to 100: 1.4006

⁵⁾ DN 65 to 80: 1.4104, DN 100: 1.4006, with metal seal

⁶⁾ Only with actuator with two diaphragms, height H +55 mm

⁷⁾ Only with mounting position with the actuator suspended (see Permissible mounting position)

⁸⁾ Only with actuator with one diaphragm, max. 80 °C, only with 0.2 bar differential pressure across the restriction

⁹⁾ Only for temperatures from –60 to +90 °C with air and gases

Application

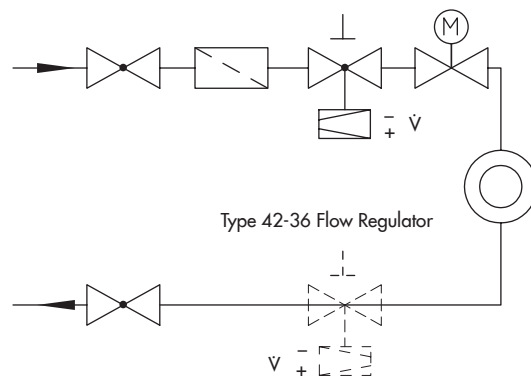

Fig. 4: Sample application for flow rate control in the flow and return flow pipes with Type 42-36

Installation of the regulators

Valve, actuator and control lines are delivered unattached.

Mount the actuator preferably after the valve is installed in the pipeline. It is connected to the bottom section of the valve with a coupling nut (11).

The following points must be observed:

- Preferably install the valve in horizontal pipelines.
- The direction of flow must match the arrow on the valve body.
- Install a strainer (e.g. SAMSON Type 2 NI) upstream of the valve.
- Valve, actuator and control line must be assembled before start-up.



Permissible mounting positions:

Suspended mounting position (standard) · Balanced by a bellows or diaphragm

- All versions
- Air and gases up to 80 °C
- Liquids up to 150 °C

Balanced by a bellows

- All media above 80 °C
- Steam applications

Upright mounting position · Balanced by a diaphragm (DN 65 and 80)

- Air and gases up to 80 °C
- Liquids up to 120 °C

Balanced by a bellows · DN 15 to 80

- All versions plus:
- Air and gases up to 80 °C
- Liquids up to 120 °C

Lying mounting position e.g. for-riser pipes · Balanced by a bellows

- Version with fixed plug guide plus:
- Air and gases up to 80 °C
- Liquids up to 120 °C

Dimensions

Dimensional drawing · Type 2423 Valve balanced by a bellows

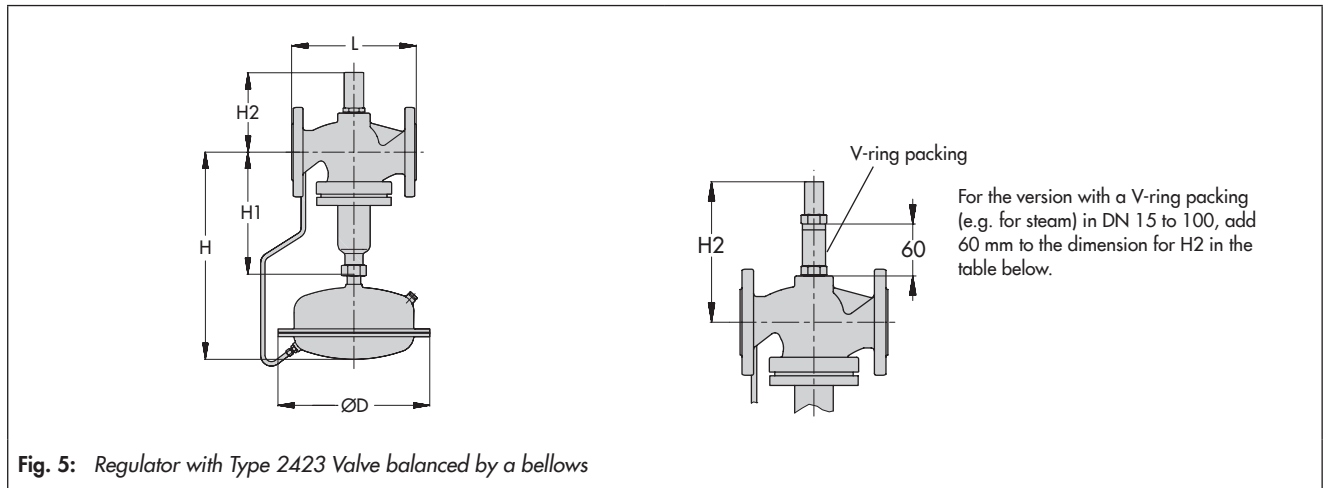

Fig. 5: Regulator with Type 2423 Valve balanced by a bellows

Table 4: Dimensions in mm and weights · Type 2423 Valve balanced by a bellows

| Valve size | DN | 15 | 20 | 25 | 32 | 40 | 50 | 65 | 80 | 100 | 125 | 150 | 200 | 250 | |
|--------------------------------------|-----------------|---|------|------|-----|------|-----|-----|-----|-----|---|-----|-----|-----|--|
| Length L | | 130 | 150 | 160 | 180 | 200 | 230 | 290 | 310 | 350 | 400 | 480 | 600 | 730 | |
| Height H1 | | 225 | | | | | | 300 | | 355 | 460 | 590 | 730 | | |
| Height H2 ¹⁾ | Forged steel | 113 | - | 130 | - | 170 | 176 | - | | | | | | | |
| | Other materials | 115 | | | 150 | | | 175 | 180 | 200 | 250 | 280 | 400 | | |
| Height H ^{5) 6)} | | 390 | | | | | | 465 | | 520 | 625 | 765 | 895 | | |
| Actuator | | (ØD = 225 mm, A = 160 cm ²) ²⁾ | | | | | | | | | (ØD = 285 mm, A = 320 cm ²) ³⁾ | | | | |
| Weight for PN 16 ⁴⁾ in kg | | 12 | 12.5 | 13.5 | 20 | 20.5 | 23 | 39 | 44 | 59 | 121 | 171 | 425 | 485 | |

¹⁾ Version with V-ring packing in DN 15 to 100: +60 mm.

²⁾ Optionally with 320 cm² actuator (DN 65 to 100). For regulators with double adapter Do2 (► T 3019) for DN 65 to 100, actuator 320 cm² recommended.

³⁾ Optionally with 640 cm² actuator

⁴⁾ Valve in PN 25/40: +10 %

⁵⁾ Minimum clearance required to remove the actuator: +100 mm

⁶⁾ Actuator with two diaphragms: Height H +55 mm · With FKM diaphragm for mineral oils

Dimensional drawing · Type 2423 Valve balanced by a diaphragm

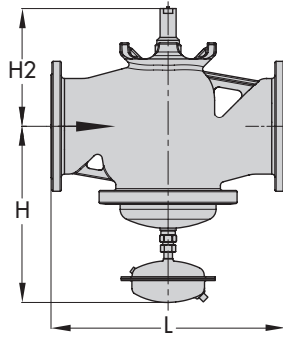

Fig. 6: Regulator with Type 2423 Valve, balanced by a diaphragm

Table 5: Dimensions in mm and weights · Type 2423 Valve balanced by a diaphragm

| Valve size | DN 65 | DN 80 | DN 100 | DN 125 | DN 150 | DN 200 | DN 250 |
|---|-------|-------|--------|--------|--------|--------|--------|
| Length L | 290 | 310 | 350 | 400 | 480 | 600 | 730 |
| Height H ^{2) 3)} | 355 | | 380 | 450 | 475 | 585 | |
| Height H2 | 195 | | 220 | 295 | 325 | 345 | 375 |
| Weight for PN 16 ¹⁾ in kg (approx.) | | | | | | | |
| Type 2423 Valve | 34 | 39 | 56 | 65 | 85 | 250 | 270 |
| Type 2426 Actuator | 7 | | 20 | | | 30 | |

¹⁾ PN 25/40: +10 %

²⁾ Minimum clearance required to remove the actuator: +100 mm

³⁾ Actuator with two diaphragms: Height H +55 mm · With FKM diaphragm for mineral oils

Ordering text

Type 42-36 Flow Regulator

DN ...

Valve balanced by a bellows/diaphragm

Body material ...

PN ...

Differential pressure at the restriction 0.2/0.5 bar

Optionally, special version ...

Optionally, accessories ... (► T 3095)