

MOUNTING AND OPERATING INSTRUCTIONS



EB 8390 EN

Translation of original instructions



Type 3738-20 Electronic Limit Switch
with optional integrated solenoid valve for on/off valves

Firmware version 1.2



Edition August 2021

Note on these mounting and operating instructions

These mounting and operating instructions assist you in mounting and operating the device safely. The instructions are binding for handling SAMSON devices. The images shown in these instructions are for illustration purposes only. The actual product may vary.

- For the safe and proper use of these instructions, read them carefully and keep them for later reference.
- If you have any questions about these instructions, contact SAMSON's After-sales Service (aftersaleservice@samsongroup.com).



Documents relating to the device, such as the mounting and operating instructions, are available on our website at www.samsongroup.com > **Service & Support > Downloads > Documentation.**

Definition of signal words

DANGER

Hazardous situations which, if not avoided, will result in death or serious injury

WARNING

Hazardous situations which, if not avoided, could result in death or serious injury

NOTICE

Property damage message or malfunction

Note

Additional information

Tip

Recommended action

1	Important safety instructions	7
1.1	Special conditions according to PTB 08 ATEX 2039 X	7
2	Article code	8
3	Design and principle of operation	9
3.1	Versions	12
3.2	Communication	13
4	Technical data	14
4.1	Electronic limit switch	14
4.2	Solenoid valve	16
5	Attachment	18
5.1	Attachment to linear actuators.....	19
5.1.1	Preparations	19
5.1.2	Attachment	20
5.2	Attachment to rotary actuators	22
5.2.1	Preparations	23
5.2.2	Attachment	24
5.3	Accessories	28
6	Connections	29
6.1	Pneumatic connections.....	29
6.2	Supply pressure	29
6.3	Electrical connection.....	30
7	Operating controls and readings	34
7.1	Rotary pushbutton	34
7.2	SAMSON SSP interface.....	34
7.3	Operating structure	35
8	Start-up	39
8.1	Adapting the display direction	39
8.2	Verifying readings on display.....	40
8.3	Determining the actuator type	41
8.4	Determining the direction of action	41
8.5	Determining the switching function of contacts.....	41
8.6	Adjusting the limit contacts	42
8.7	Initialization	42
8.7.1	Start automatic initialization	43
8.7.2	Start manual initialization.....	44

Contents

8.8	Replacing an electronic limit switch.....	45
8.9	Zero/end position calibration	46
8.10	Reset to default settings.....	46
9	Operation	47
9.1	Lock operation	47
9.2	Partial stroke test (PST).....	47
9.2.1	Defining the PST target range.....	49
9.2.2	Starting the partial stroke test	50
9.2.3	Example: PTO direction of action.....	50
9.3	Testing the contacts.....	53
9.4	Testing the solenoid valve.....	54
9.5	Malfunctions.....	55
9.5.1	Status messages.....	55
9.5.2	Error messages	55
9.5.3	Confirming status and error messages	55
10	Maintenance, calibration and work on equipment	56
10.1	Servicing.....	56
11	Servicing explosion-protected devices	56
12	Firmware update (serial interface).....	57
13	Disposal.....	57
14	Parameter list.....	58
14.1	Status messages.....	62
14.2	Error messages	64
15	Dimensions in mm.....	66
15.1	Fixing levels according to VDI/VDE 3845 (September 2010)	69
	Assignment based on the direction of action	83

Firmware revisions	
Firmware	Revisions
1.12	<p>Changes to parameters and error messages (see section 13)</p> <ul style="list-style-type: none"> Parameters renumbered due to parameters being added or removed. <ul style="list-style-type: none"> Removed parameters: <ul style="list-style-type: none"> 'PST initialization' (the partial stroke test no longer needs to be initialized). Info: Rotary motions New parameters: <ul style="list-style-type: none"> 'Actuator type' (rotary or linear actuator). See section 8.3. 'Switching function of contacts' (NO or NC contact). See section 8.5. Error messages renumbered due to error messages being removed. <ul style="list-style-type: none"> Removed error messages: <ul style="list-style-type: none"> 'PST target range not reached' 'PST target range exceeded' The new parameter 'Actuator type' as well as the 'Actuator's direction of action' parameter are locked after the electronic limit switch has been initialized. See sections 8.3 and 8.3. The actuator transit time monitoring (F4) depends on the value adjusted in 'Status readout for actuator transit time (P13). This is adjustable between 0 (OFF) and 1800 s. The dead time is already included in the information parameters 'Actuator transit time when the solenoid valve is de-energized' and 'Actuator transit time when the solenoid valve is energized'. The monitoring of the rotary motion counter can be deactivated by configuring 'Maximum rotary motions' (P26) = OFF. <p>Changes to the partial stroke test (PST) (see section 9.2)</p> <ul style="list-style-type: none"> The minimum pulse length at contact C is three seconds during partial stroke testing. The PST target range is made up of 'PST step end (P14) \pm 1/2 'PST tolerance band' (P15). Once a partial stroke test has been completed, the assessment of the transit times when the solenoid valve is de-energized and energized ('PST transit time when the solenoid valve is de-energized' and 'PST transit time when the solenoid valve is energized'). Only the duration of the entire test is shown in version 1.01. In the TROVIS-VIEW software, a diagram plotting the valve position against time while the solenoid valve is de-energized and energized is shown (256 measuring points). The data can be read out by connecting the device at the SSP interface to a computer.

Firmware revisions	
Firmware	Revisions
1.20	<p>Changes to parameter readings on the display</p> <ul style="list-style-type: none"> • P3 Verify LCD segments: TSTD reading (see section 8.2) • P9 Automatic initialization: INIA reading (see section 8.7) • P10 Manual initialization: INIM reading (see section 8.7) • P11 End position calibration: REF reading (see section 8.9) • P17 Start manual PST: PST reading (see section 9.2) • P19 Testing contacts: TSTC reading (see section 9.3) • P20 Testing solenoid valve: TSTS reading (see section 9.4) • P21 Reset: RST reading (see section 8.10) <p>New status message F15 The status is generated when the configuration mode SET is activated.</p> <p>Changes to the partial stroke test (PST) (see section 9.2) A canceled partial stroke test (PST) is logged with a time stamp in TROVIS-VIEW.</p>

i Note

The device with a CE marking fulfills the requirements of the Directives 2014/30/EU and 2011/65/EU as well as 2014/34/EU depending on the version.

1 Important safety instructions

For your own safety, follow these instructions concerning the mounting, start up and operation of the limit switch:

- The device is to be mounted, started up or operated only by trained and experienced personnel familiar with the product. According to these mounting and operating instructions, trained personnel is referred to as individuals who are able to judge the work they are assigned to and recognize possible dangers due to their specialized training, their knowledge and experience as well as their knowledge of the applicable standards.
- Explosion-protected versions of this device must be operated only by personnel who has undergone special training or instructions or who is authorized to work on explosion-protected devices in hazardous areas.
- Any hazards that could be caused by moving parts are to be prevented by taking appropriate precautions.
- For use within hazardous areas, the Special Conditions mentioned in the EC type examination certificate and its addenda must be observed.
- If inadmissible motions or forces are produced in the pneumatic actuator as a result of the supply pressure level, it must be restricted using a suitable supply pressure reducing station.

To avoid damage to any equipment, the following also applies:

- Proper shipping and storage are assumed.
- Do not ground electric welding equipment near to the electronic limit switch.

1.1 Special conditions according to PTB 08 ATEX 2039 X

An appropriate warning is to be attached to the plastic part of the enclosure to prevent the risk of electrostatic charging.

Where it is necessary to protect the apparatus against mechanical influences the installation instructions in the mounting instructions document must be observed.

2 Article code

Type 3738-20 Electronic Limit Switch	x	x	x	1	x	0	0	x	x	x	2	0	x
With LCD													
Explosion protection													
Without	0	0	0										
ATEX: II 2G Ex ia IIC T6; II 2D Ex ia IIIC T80°C IP66	1	1	0										
ATEX: II 2G Ex eb[ia] IIC T4; II 2D Ex tb IIIC T80°C IP66	3	1	0	0									
ATEX: II 3G Ex ic IIC T4; II 3G Ex nA II T4 Gc; II 3D Ex tc IIIC T80°C IP66	8	1	0										
Solenoid valve													
External				0									
Integrated				4									
Company version													
SAMSON								0					
AIR TORQUE ¹⁾								1					
Housing													
Standard aluminum, black structured, RAL 9005										1			
Cover													
Gray beige											0		
Black ¹⁾											1		
Silver gray ¹⁾											3		
Special applications													
Without													0

¹⁾ No longer available after January 2018

3 Design and principle of operation

The Type 3738-20 Electronic Limit Switch can replace conventional solenoid valves and limit switches used for the automation of on/off valves without the need to change the wiring or signal level. Major features of the electronic limit switch include:

- Unification of the functions featured in limit switches and a solenoid valve in one housing
- Power supplied in a two-wire system from the connection of contact A, without the need for an additional power supply
- Non-contact sensing of the rotation angle by a magnetoresistive sensor system
- Integrated diagnostics with partial stroke testing (PST)

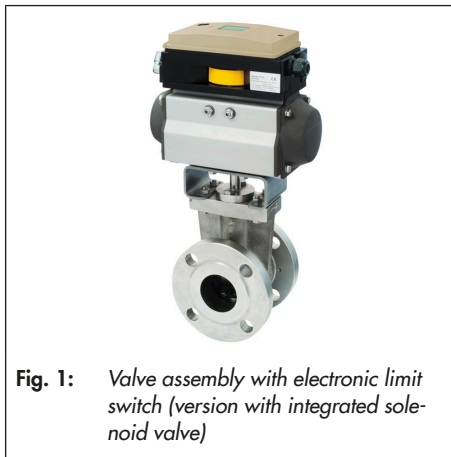

Fig. 1: Valve assembly with electronic limit switch (version with integrated solenoid valve)

Fig. 2 and Fig. 3

The electronic limit switch is designed for attachment to linear and rotary actuators. The travel is measured without contact using a magnet (on a screw) positioned centrally on the actuator shaft. The screw with magnet does not need to be adjusted. The AMR (anisotropic magnetoresistive) sensor located in the device together with the measuring electronics (1) can detect the directional change of the applied magnetic field and, as a result, sense the movement of the actuator.

The actuator is operated by a solenoid valve (7) which converts the binary signal issued by the electric control equipment (6) into a binary pressure signal.

The electronic limit switch has four NAMUR contacts: the limit switch for fail-safe position (contact A, 13) and the limit switch for operating position (contact B, 14) issue a limit signal when the valve reaches the corresponding end position. Contact C (15) indicates when a third limit is reached or the PST target range of the partial stroke test has been reached. The switching response of the contacts can be adjusted within the travel range. The fault alarm contact St (16) indicates the generation of any status and error messages.

An electronic limit switch version for an external solenoid valve (Fig. 3) is available for higher air capacities required by large actuators. The principle of operation is the same.

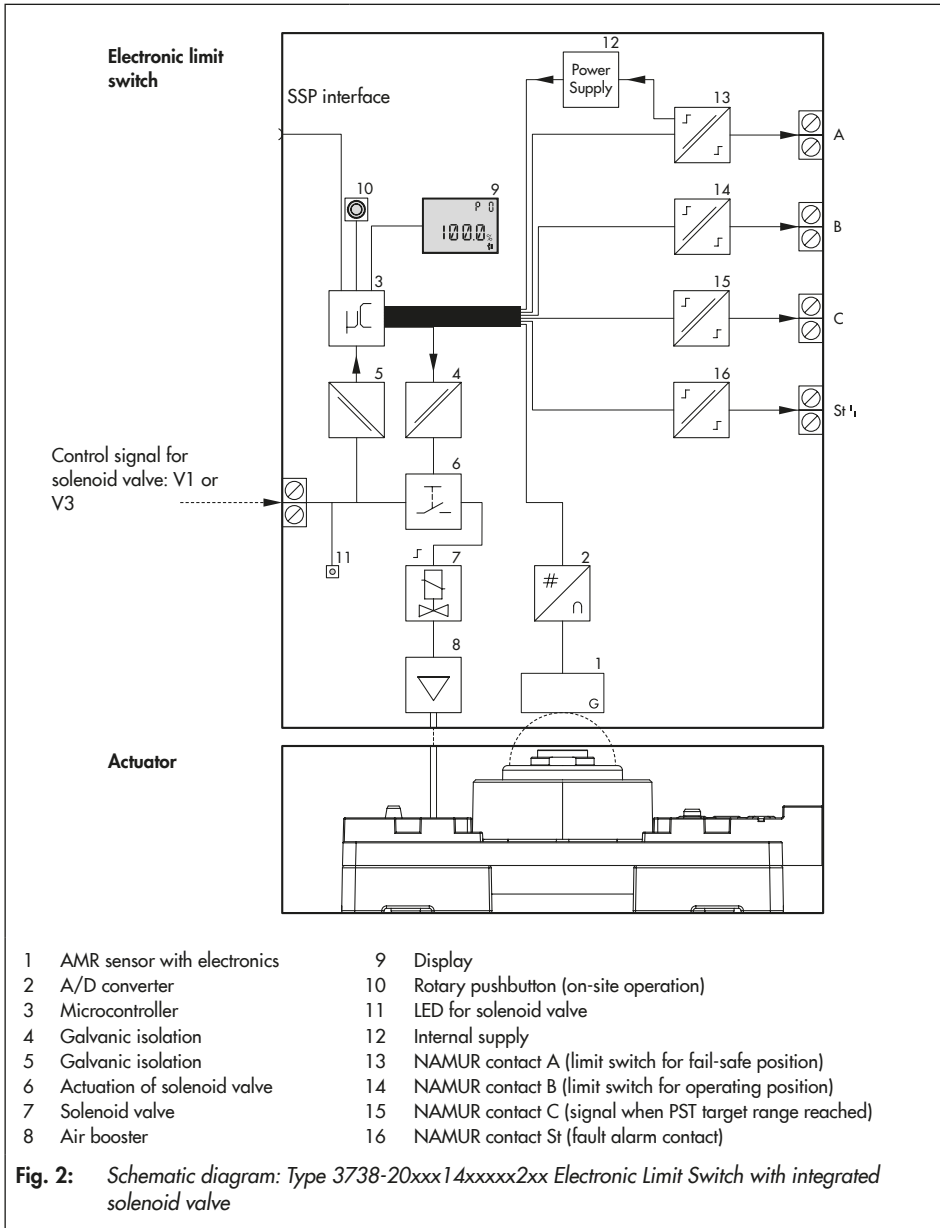

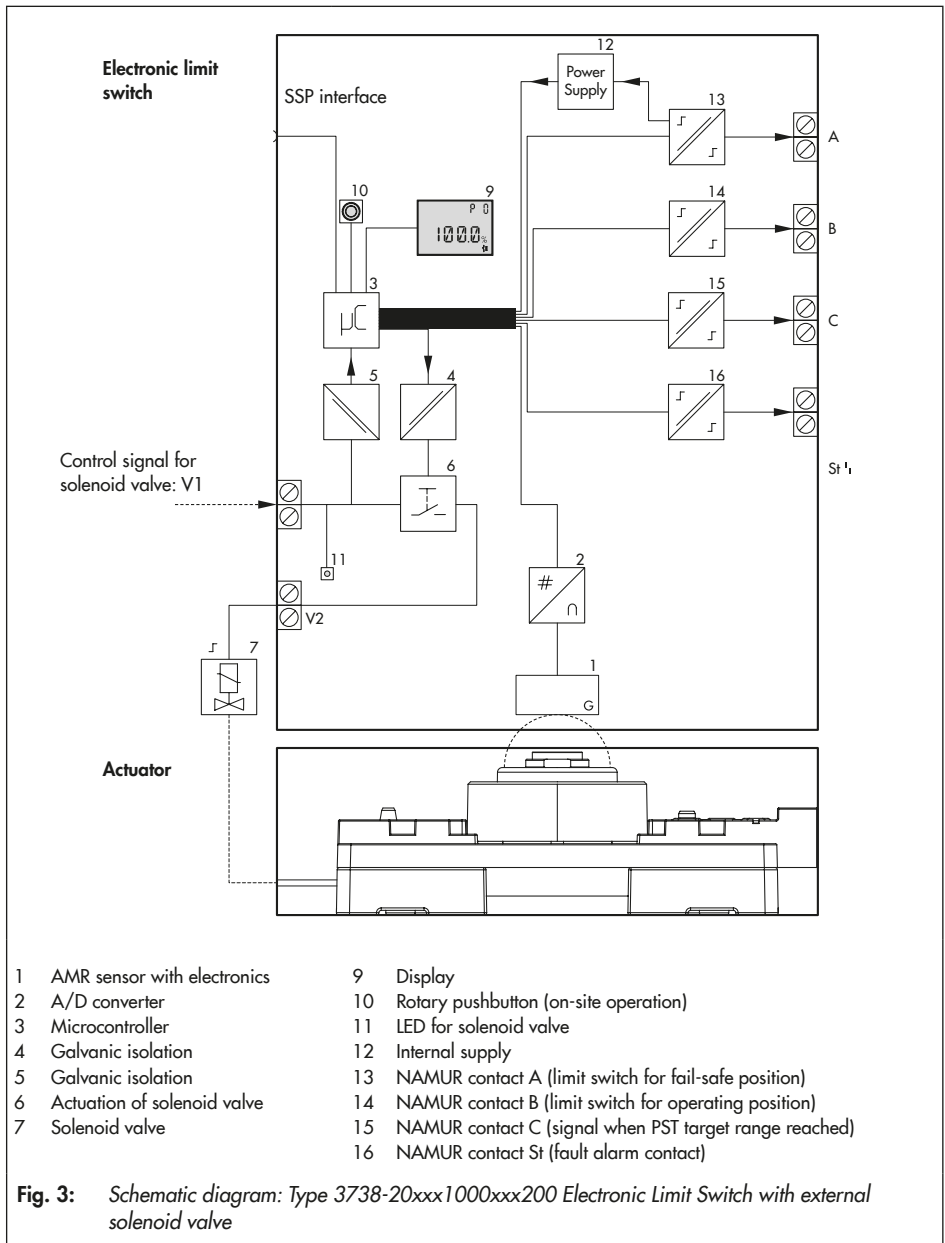

Design and principle of operation

NAMUR contacts A, B, C

The contacts can be configured as either NO or NC contacts. See Fig. 4 and section 8.5.

NAMUR contact St

This contact is a NC contact.

3.1 Versions

Type 3738-20xxx14xxxxx2xx Electronic Limit Switch with integrated solenoid valve

The electronic limit switch with integrated solenoid valve form a compact unit together with a pneumatic actuator, which is easy to mount. The 3/2-way or 5/2-way function of the solenoid valve is selected by changing the position of a molded seal.

Type 3738-20xxx1000xxx200 Electronic Limit Switch with external solenoid valve

The electronic limit switch for an external solenoid valve allows switching capacities up to max. 18 W at 24 V DC, meaning all common solenoid valves, even the Ex e versions, can be combined with the electronic limit switch. This version is suitable for rotary actuators according to VDI/VDE 3845, level 1. See Fig. 8.

Changes to the electronic limit switch's settings do not effect the external solenoid valve.

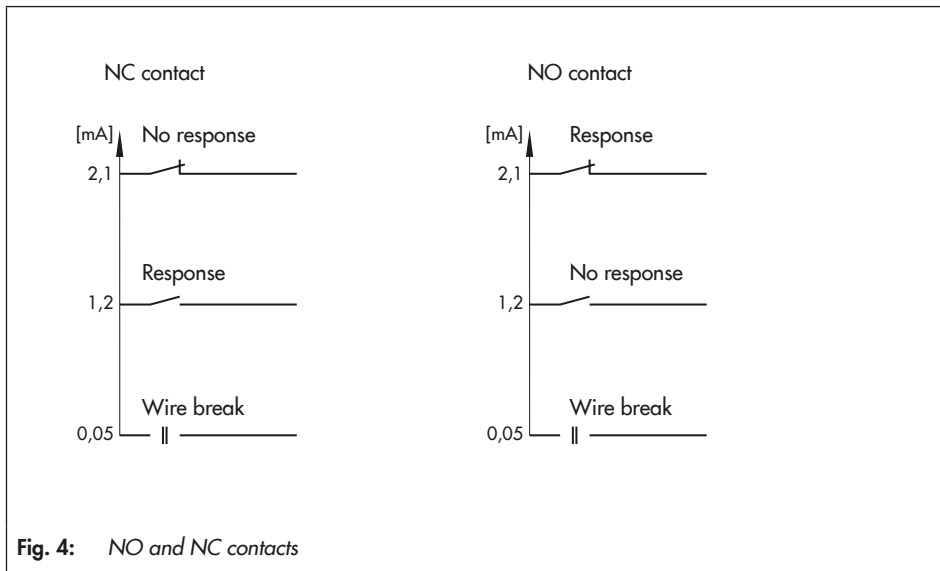

Fig. 4: NO and NC contacts

3.2 Communication

The electronic limit switch can be configured with SAMSON's TROVIS-VIEW Software.

The electronic limit switch has for this purpose a SAMSON SSP interface to allow the RS-232 or USB port of a computer to be connected to it using a serial interface adapter cable. The TROVIS-VIEW software enables the user to easily configure the electronic limit switch as well as view and document process parameters on a computer. See Table 3 for order numbers.

i Note

TROVIS-VIEW provides a uniform user interface that allows users to configure and parameterize various SAMSON devices using device-specific database modules. The Type 3738-20 device module can be downloaded free of charge from our website (www.samsongroup.com) at Services > Software > TROVIS-VIEW. Further information on TROVIS-VIEW (e.g. system requirements) is available on our website and in the Data Sheet ► T 6661.

4 Technical data



4.1 Electronic limit switch

Electronic Limit Switch Type		3738-20xxx14xxxxx2xx	3738-20xxx1000xxx200
Implementation		With integrated solenoid valve	For external solenoid valve
Permissible range of rotation		Min.: 0 to 30° Max.: 0 to 170°	
Communication	Local communication	SAMSON SSP interface with serial interface adapter	
	Software	TROVIS-VIEW with database module 3738-20	
Supply air	Supply air	2.4 to 8 bar	Same as specifications of the solenoid valve manufacturer
	Air quality	According to ISO 8573-1 Max. particle size and density: Class 4 Oil content: Class 3 Moisture and water: Class 3 Pressure dew point: at least 10 K below the lowest ambient temperature to be expected	
	Air consumption	In idle position <60 l/h In switching position <30 l/h	
Electric power supply		Powered over contact A acc. to DIN EN 60947-5-6 (e.g. NAMUR isolating switch amplifier)	
Permissible ambient temperature The temperature limits for the explosion-protected devices may be restricted by the limits specified in the test certificates.		-25 to 80 °C	-40 to 80 °C Metal cable glands must be used for ambient temperatures below -20 °C.
Influences	Temperature	±0.7 %/90° angle above the permissible temperature range	
	Effect of vibration	≤0.25 % up to 2500 Hz and 4 g according to IEC 770	
Service life		15 years	
Maximum storage period		24 months	
Electromagnetic compatibility		Complying with EN 61000-6-2, EN 61000-6-3, EN 61326-1 and NAMUR Recommendation NE 21	
Electrical connections		Four M20x1.5 cable glands for 6 to 12 mm clamping range, screw terminals for 0.2 to 2.5 mm ² wire cross-sections	
Explosion protection		Refer to Table 1	
Degree of protection		IP 66	

Electronic Limit Switch Type		3738-20xxx14xxxxx2xx	3738-20xxx1000xxx200
Implementation		With integrated solenoid valve	For external solenoid valve
Materials	Housing	Die-cast aluminum EN AC-ALSi12(Fe) (EN AC-44300) acc. to DIN EN 1706, powder coating	
	Housing cover	PC	
	Cover gasket	PU	
	Indicator wheel	PC	
	Magnet material	Hard ferrite	
Weight		Approx. 1.2 kg	Approx. 1.0 kg
Conformity			
Switching function		NC contact	NO contact
Switching contacts	No response/no fault	≥ 2.2 mA	≤ 1.0 mA
	Response/fault indication	≤ 1.0 mA	≥ 2.2 mA
Hysteresis		1 %	
Contacts	Contact A Limit contact for fail-safe position (solenoid valve de-energized)	PTO (power to open): responds when the valve moves through the switching contact towards the lower end position (P7) PTC (power to close): responds when the valve moves through the switching contact towards the upper end position (P8)	
	Contact B Limit contact for operating position (solenoid valve energized)	PTO (power to open): responds when the valve moves through the switching contact towards the upper end position (P8) PTC (power to close): responds when the valve moves through the switching contact towards the lower end position (P7) Signal for wire breakage according to DIN EN 60947-5-6	
	Contact C Signal when target range reached during partial stroke test	Responds when the valve reaches the PST target range* * PST target range = 'PST step end' (P14) \pm 1/2 'PST tolerance band' (P15)	
Contacts	Contact C Limit contact for intermediate position	PTO (power to open): responds when the valve moves through the switching contact towards the operating position (P14) PTC (power to close): responds when the valve moves through the switching contact towards the fail-safe position (P14)	
	Contact St Fault alarm contact	Responds when a status message or error message is generated (always NC contact).	
Current specifications when contact A is not connected		Contact B: $I \leq 50$ μ A (wire breakage) Contact C: $I \leq 1.0$ mA Contact St: $I \leq 1.0$ mA	

Technical data

Table 1: Explosion protection certificates for Type 3738-20 Electronic Limit Switch

Type	Certification		Type of protection/comments	
3738-20	-110	 ¹⁾	Number PTB 08 ATEX 2039 X	II 2G Ex ia IIC T6; II 2D Ex ia IIIC T80°C IP66
		Date 2012-07-19		
	-310	 ¹⁾	Number PTB 08 ATEX 2039 X	II 2G Ex eb[ia] IIC T4; II 2D Ex tb IIIC T80°C IP66
		Date 2012-07-19		
	-810	 ¹⁾	Number PTB 08 ATEX 2039 X	II 3G Ex ic IIC T4; II 3G Ex nA II T4 Gc; II 3D Ex tc IIIC T80°C IP66
		Date 2012-07-19		

¹⁾ EC type examination certificate

4.2 Solenoid valve

Integrated solenoid valve (Type 3738-20xxx14xxxxx2xx)	
Current draw	$I = \frac{2,7}{3650} \cdot U - 3.325 \text{ mA}$ (corresponding to 14.4 mA at 24 V)
Version	3/2-way or 5/2-way function Function determined by the position of the molded seal
K_{VS} coefficient	0.32
Service life	1,000,000 switching cycles
Temperature range (operation)	-25 to +80 °C
Switching voltage	Nominal voltage 24 V DC, reverse polarity protection, galvanic isolation
	Signal 0 When the voltage falls below 15 V DC
	Signal 1 Min. 18 V DC
Switching capacity	24 V DC; 15.2 mA (0.36 W)
Duty cycle	100 %
Static destruction limit	32 V DC

External solenoid valve (Type 3738-20xxx1000xxx200 Electronic Limit Switch)		
Read manufacturer's specifications.		
24 V DC, max. 18 W		
Switching voltage	Signal 0	When the voltage falls below 15 V DC
	Signal 1	Min. 18 V DC
Static destruction limit		32 V DC

5 Attachment

DANGER

– **Electrostatic charging**

Due to the high surface resistance of the enclosure cover ($R_{isol.} \geq 10^9 \Omega$), installation and maintenance on the equipment must be performed in such a way as to prevent electrostatic charging.

– **Mechanical effects**

In areas where damage to the housing can be expected due to mechanical influences, the housing must be protected by an additional cover.

– **Combustible dust atmospheres**

The electronic limit switch complies with the requirements for type of protection Ex tb as the enclosure (housing) is designed according to EN 60079-31. The enclosure complies with degree of protection IP 66 according to IEC 60529.

WARNING

Mount the electronic limit switch, keeping the following sequence:

- Mount the electronic limit switch on the actuator. See sections 5.1 and 5.2.
- Connect the supply air. See sections 6.1 and 6.2.
- Connect the electrical power. See section 6.3.
- Perform the start-up settings. See section 8.

NOTICE

Observe the following instructions to avoid damaging the electronic limit switch:

- Use only the accessories listed in the Table 3 to mount the electronic limit switch.
- Observe the shaft height of the actuator on mounting the electronic limit switch on rotary actuators!

Mounting position

Any mounting position may be used, however, the electronic limit switch must not be installed in a suspended position.

5.1 Attachment to linear actuators

The electronic limit switch is mounted to linear actuators according to IEC 60534-6 (NAMUR attachment).

Required accessories:
see Table 3 page 28

5.1.1 Preparations

Version with integrated solenoid valve
(Type 3738-20xxx14xxxxx2xx) (Fig. 5)

1. Insert the molded seal (3) into the support element (2) depending on the type of actuator (single-acting or double-acting).

2. Slide the O-ring (3.1) onto the air duct of the molded seal (3).
3. Fasten the electronic limit switch (1) to the support element (2) using the two screws mounted on the electronic limit switch as shown in Fig. 5.
4. Remove the blanking plug on the supply air port (SUPPLY, 2.1) of the support element (2).

Version with external solenoid valve
(Type 3738-20xxx1000xxx200)

1. Fasten the electronic limit switch (1) to the support element (2) using the two screws mounted on the electronic limit switch as shown in Fig. 5.

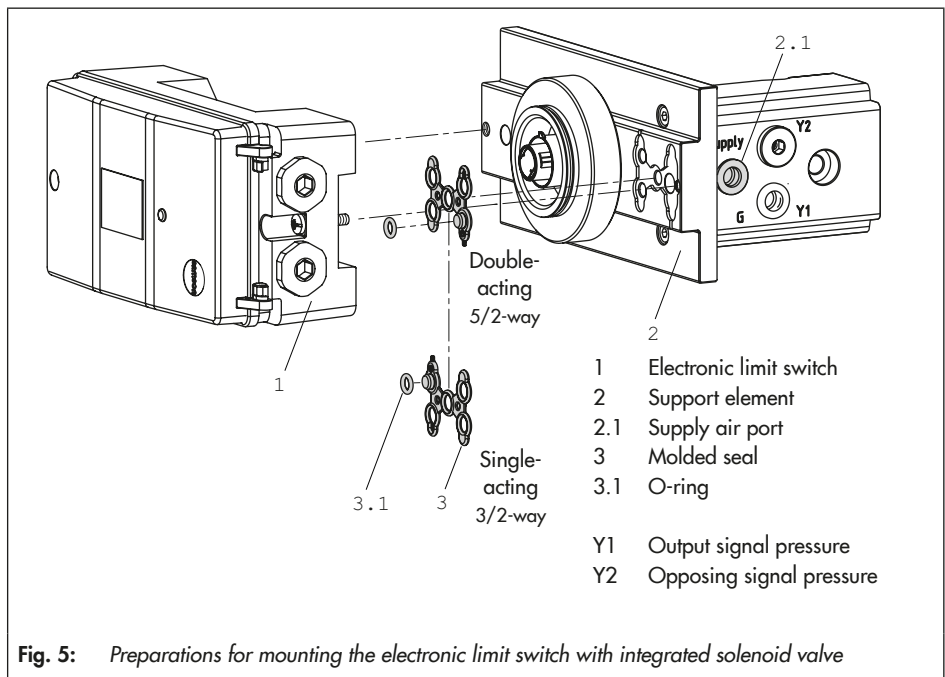

Attachment

5.1.2 Attachment

Use the lever (5) underneath the support element (2) and the pin (6) on the lever to adapt the electronic limit switch to the linear actuator.

Table 2: Travel table

Actuator size [cm ²]	Rated travel [mm]	Lever	Recommended pin position
120 to 350	15	M	35
700	15/30	M	50
1400	60	L	100
2800	120	XL	200
2800	30	M	50
2800	60	L/XL	100/200

The electronic limit switch is equipped with the lever M (pin position 35) as standard.

Levers L and XL are included in the mounting parts 1402-0544 or 1402-0545.

1. Select lever (5) according to Table 2.
2. Insert the follower pin (6) in the pin position according to Table 2 of the lever (5). Fasten tight using shim and nuts (Fig. 6).
3. Place the lever (5) on the shaft of the support element (2) and fasten it tight using the disk spring (5.1) and nut (5.2).
4. **Mounting to actuators with 120 to 700 cm² actuator areas (Fig. 7 1):**
Fasten the follower plate (7.1) at the middle holes to the stem connector (9) of the actuator using the washers (7.2) and screws (7.3).

Mounting to Type 3271 Actuators with 1400 and 2800 cm² actuator areas and with 200 mm rated travel (Fig. 7 2)

Fasten the follower plate (7.4) at the outer holes to the stem connector (9) of the actuator using the screws (7.5).

Mounting to Type 3271 Actuators with 2800 cm² actuator area and with 50, 100 or 200 mm rated travel (Fig. 7 3)

Screw the bracket (8) to the stem connector (9) of the actuator using the screws (8.2).

Fasten the follower plate (7.1) together with pins (8.1) located in the middle holes to the bracket (8) using the washers (7.2) and screws (7.3).

5. Fasten the support element (2) to the actuator using the screw (4), ensuring that the follower pin (6) comes to rest in the slot of the follower plate (7.1/7.4).
6. Electronic limit switch with integrated solenoid valve: connect supply air to supply air port (SUPPLY, 2.1).

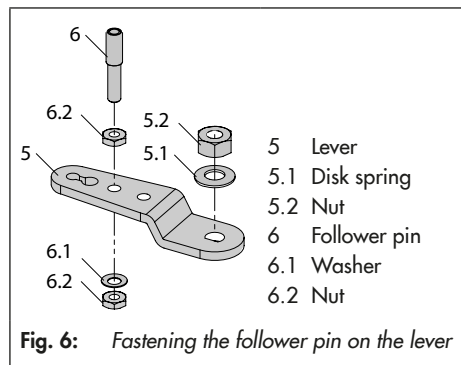

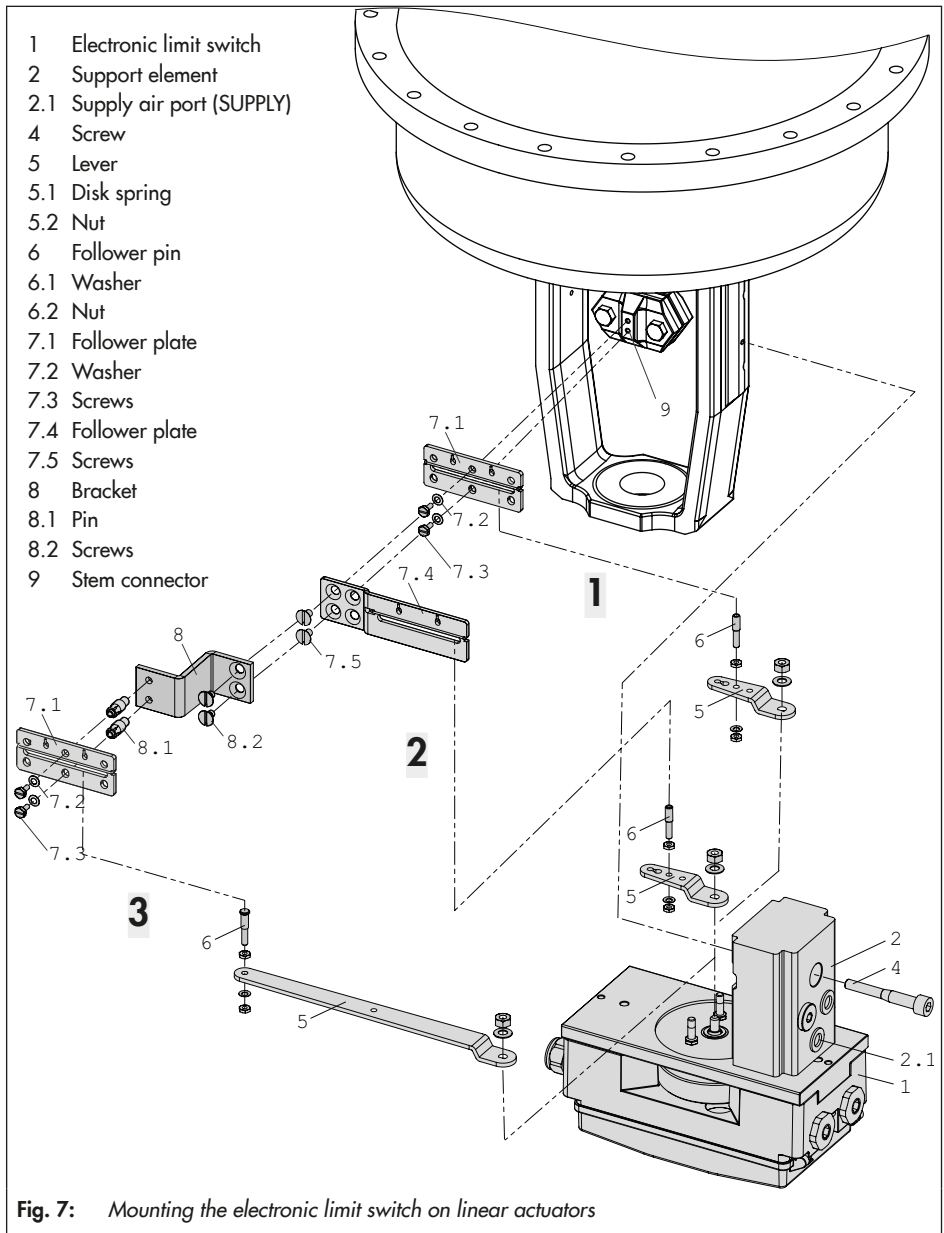

5.2 Attachment to rotary actuators

The electronic limit switch is mounted on rotary actuators according to VDI/VDE 3845, level 1 (2010). The version with integrated solenoid valve can also be directly (without hook-up) mounted to a Pfeiffer Type 31a Rotary Actuator (Edition 2020+) (Fig. 8).

Required accessories: see Table 3 page 28

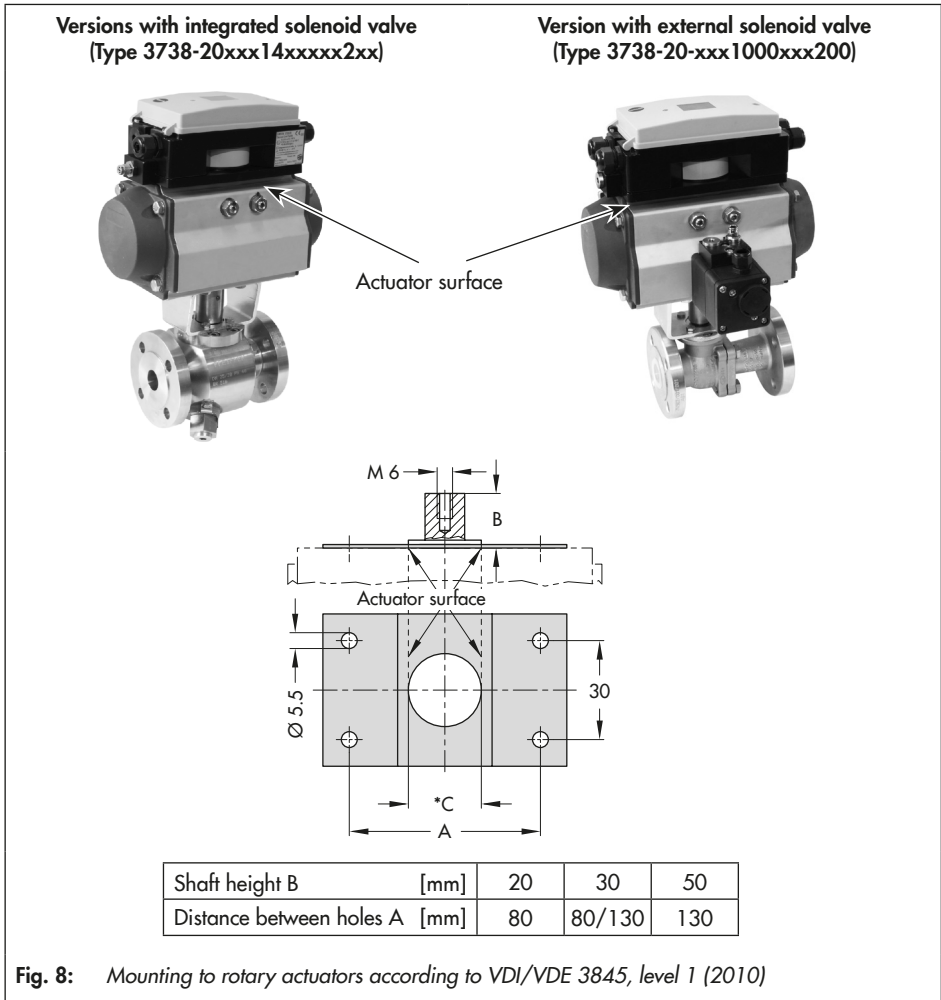

5.2.1 Preparations

Version with integrated solenoid valve (Type 3738-20xxx14xxxxx2xx)

Two mounting platforms are available for the attachment (Fig. 9):

- Mounting platform for mounting onto the special version of the Pfeiffer Type 31a Rotary Actuator with integrated air holes
- Mounting platform for freely configurable hook-up for mounting to standard actuators according to VDI/VDE 3845

The supply air is connected at the side of both mounting platforms. The blanking plug needs to be removed from the air connection (Fig. 9).

1. Insert the molded seal (3) into the mounting platform (2) depending on the type of actuator (single-acting or double-acting).
2. Slide the O-ring (3.1) onto the air duct of the molded seal (3).

3. Press the molded seal (4) onto the air ducts underneath the mounting platform (2).
4. **For attachment to rotary actuators with a 50 mm shaft height:** press the second molded seal (4) onto the air ducts underneath one of the distance pieces (5).
5. Remove the blanking plug on the supply air port (SUPPLY) of the mounting platform (2).
6. Connect the connections (depending on the mounting platform):

Mounting platform for freely configurable hook-up, single-acting actuator

- ➔ Connect port 138 to the pneumatic actuator
- Without air purging of the actuator's spring chamber:
seal port 238 with the blanking plug
 - With air purging of the actuator's spring chamber:

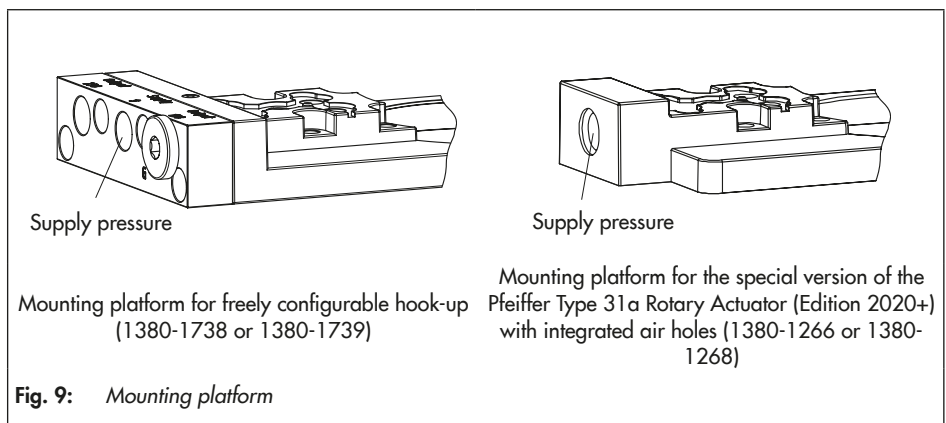

Attachment

connect port 238 to the actuator's spring chamber

Mounting platform for freely configurable hook-up, double-acting actuator

- Connect port 138 to the chamber of the pneumatic actuator, that opens the valve when loaded with air
- Connect port 238 to the other chamber of the actuator

Mounting platform for Pfeiffer Type 31a Rotary Actuator (Edition 2020+) with integrated air holes

- Connect internally using the molded seal (4)

Version with external solenoid valve (Type 3738-20xxx1000xxx200)

No preparation is necessary.

5.2.2 Attachment

The attachment depends on the shaft height of the rotary actuator upon which the electronic limit switch is to be mounted (Fig. 11).

	Screw with magnet (6)	Cap screws (10)
20 mm shaft height	SW 24, 30 mm	M5x16
30 mm shaft height	SW 24, 20 mm	M5x16
50 mm shaft height	SW 24, 20 mm	M5x40
80 mm shaft height	SW 24, 20 mm	M5x40

1. Attachment to rotary actuators with 20 or 30 mm shaft height:

Place the spacers (11) on the inner holes of the actuator.

Attachment to rotary actuators with 50 mm shaft height:

Place the distance pieces (5) on the rotary actuator.

Attachment to rotary actuators with 80 mm shaft height:

- a. Screw pins (16) into the actuator.
- b. Fasten adapter (14) with anti-rotation fixture (15) in the groove of the actuator shaft.
- c. Bend the flap on the anti-rotation fixture (15) upward.
- d. Fasten intermediate plate (13) to the pins (16) using the screws (12).

i Note

Electronic limit switch with integrated solenoid valve: place the distance piece including inserted molded seal (4) over the air ducts of the actuator.

2. Fasten the mounting platform (2) on the rotary actuator:
 - **Version with integrated solenoid valve:** screws 10a and 10b
 - **Version for external solenoid valve:** screws 10a

i Note

Electronic limit switch with integrated solenoid valve: fasten the mounting platform (2), making sure that the air ducts located on the rotary actuator and the mounting platform are properly aligned over each other.

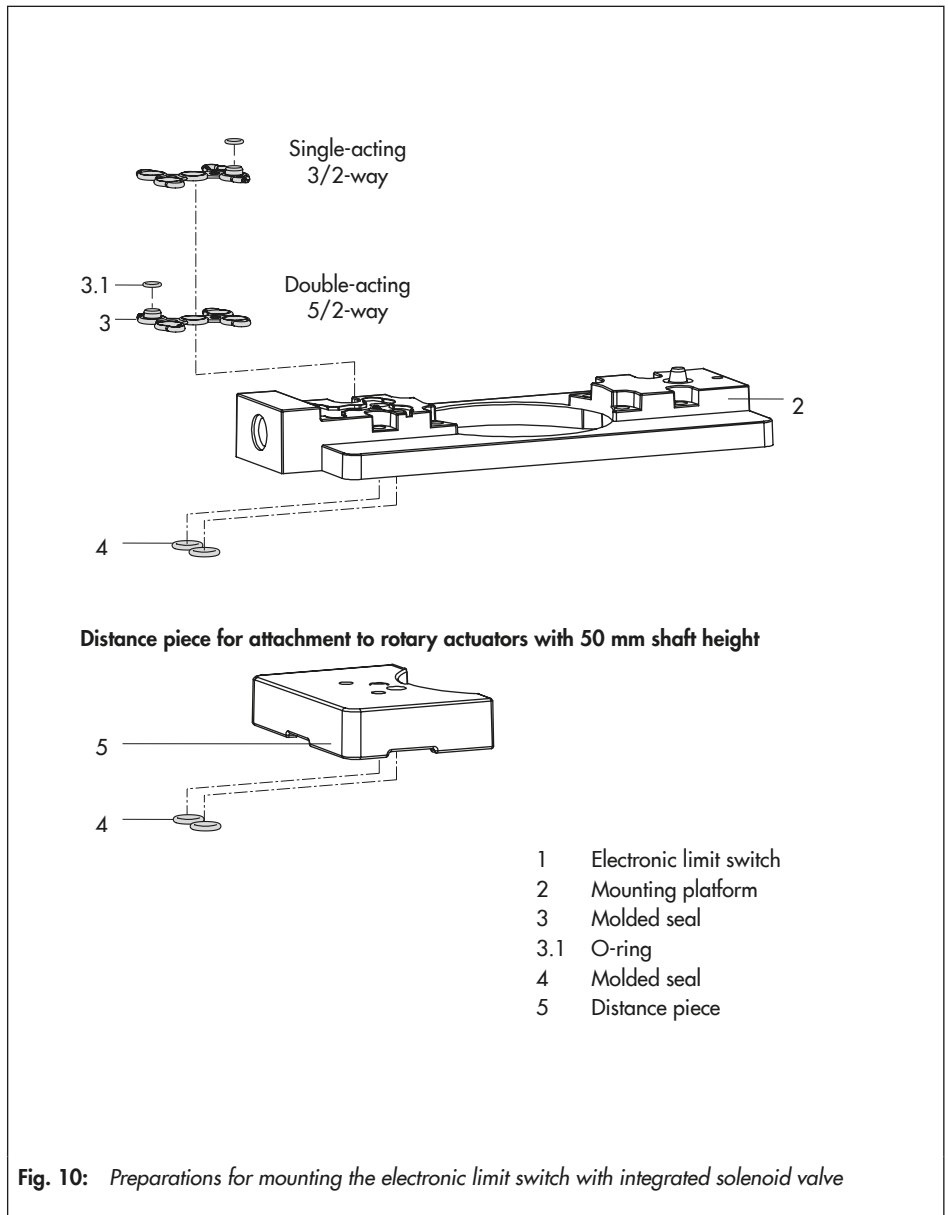

Attachment

3. Attachment to rotary actuators with 20 mm shaft height:

Place the adapter (7) and indicator wheel (8) one after the other onto the actuator shaft.

Attachment to rotary actuators with 30, 50 or 80 mm shaft height:

Place the indicator wheel (8) onto the actuator shaft.

4. Insert plate (9) into the indicator wheel (8).

NOTICE

Do not exceed the maximum torque of 8 Nm when fastening the screw with magnet (6).

5. Fasten the screw with magnet (6) onto the actuator shaft.
6. Bend the two flaps on the plate (9) towards the width flats of the screw with magnet (6).
7. Place the electronic limit switch on the mounting platform (2) as shown in Fig. 11 and fasten it using the two screws mounted on the device.
8. Electronic limit switch with integrated solenoid valve: connect supply air to supply air port (SUPPLY, 2.1).

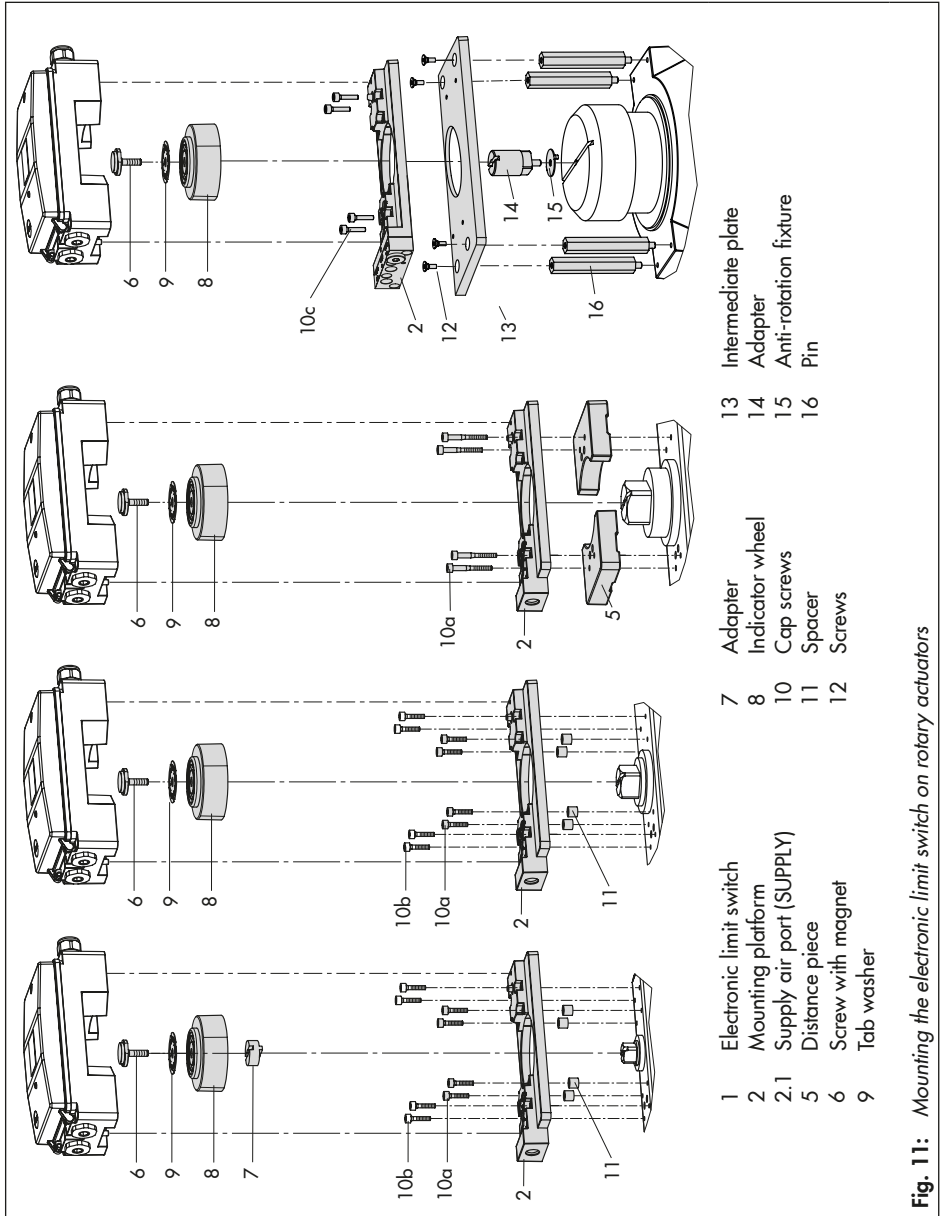

Fig. 11: Mounting the electronic limit switch on rotary actuators

5.3 Accessories

Table 3: *Accessories*

		Order no.	
Attachment to linear actuators (NAMUR attachment)	Version with integrated solenoid valve	G 1/4	1402-0540
	Version with integrated solenoid valve	1/4 NPT	1402-0541
	Version for external solenoid valve	G 1/4	1402-0542
	Version for external solenoid valve	1/4 NPT	1402-0543
	Plus mounting parts for Type 3271 Actuator Version up to 700 cm ² 1400-60 and 2800-120 versions 2800-30 and 2800-60 versions		– 1402-0544 1402-0545
Attachment to rotary actuators acc. to VDI/VDE 3845, fixing level 1 (2010) * See section 1.4.1 for dimensions	Size AA1* (20 mm shaft height)		1400-9859
	Size AA2* and AA3 (30 mm shaft height)		1400-9860
	Size AA4* (50 mm shaft height)		1400-9861
	Size AA4 in special version (50 mm shaft height, 88 mm shaft diameter), e.g. AIR TORQUE Type SC 3000 and Pfeiffer Type 31b, 2000 to 5000 size		1402-0332
	Size AA5* (80 mm shaft height)		1402-0586
	VDI/VDE 3845 mounting platform for freely configurable hook-up G 1/4		1380-1738
	VDI/VDE 3845 mounting platform for freely configurable hook-up 1/4 NPT		1380-1739
	Mounting platform for Type 31a Edition 2020+ (black)	G 1/4	1380-1266
	Mounting platform for Type 31a Edition 2020+ (black)	1/4 NPT	1380-1268
Cable glands (M20x1.5)	Nickel-plated brass		1880-4875
	Stainless steel 1.1305		8808-0160
	Version for Ex i: black plastic		8808-0180
	Version for Ex i: blue plastic		8808-0181
SAMSON TROVIS-VIEW software	TROVIS-VIEW with device module 3738-20 (free download from www.samsongroup.com)		
	Serial interface adapter (SAMSON SSP interface to RS-232 port on a computer)		1400-7700
	Isolated USB interface adapter (SAMSON SSP interface to USB port on a computer)		1400-9740

6 Connections

⚠ WARNING

Mount the electronic limit switch, keeping the following sequence:

- Mount the electronic limit switch on the actuator. See sections 5.1 and 5.2.
 - Connect the supply air. See sections 6.1 and 6.2.
 - Connect the electrical power. See section 6.3.
 - Perform the start-up settings. See section 8.
- The connection of the power may cause the actuator shaft/stem to move, depending on the operating mode.

Do not touch the actuator shaft/stem or obstruct it to avoid risk of injury to hands or fingers.

6.1 Pneumatic connections

ⓘ NOTICE

Observe the following instructions to avoid damaging the electronic limit switch and/or solenoid valve.

- Run and attach the connecting lines and screw joints according to good professional practice. Check them for leakage and damage at regular intervals and repair them, if necessary. Before starting any repair work, depressurize any open connecting lines.
- The air connections are designed as threaded holes with G ¼ or ¼ NPT thread depending on the device version. Protect the exhaust air connections or vent plugs

by installing a filter or taking other appropriate precautions to prevent water or dirt from entering them.

- **Operation using a pressure reducing valve:** The K_{VS} coefficient of an upstream pressure reducing valve must be at least 1.6 times larger than the K_{VS} coefficient of the device.
- **Air pipe:** The minimum nominal size of the air pipe must be a pipe with an inside diameter of ≥ 4 mm. A larger nominal size is needed when the connection length exceeds 2 m.
- **Operation with external solenoid valve (Type 3738-20xxx1000xxx200):**
The input pressure must not exceed the maximum supply pressure of the external solenoid valve (refer to the specifications given by the solenoid valve manufacturer). Do not remove the blanking plug on the air port of the mounting platform (3).
- The supply air must be dry and free from oil and dust. The maintenance instructions for upstream pressure reducing stations must be observed.
- Blow through all air pipes and hoses thoroughly before connecting them.

6.2 Supply pressure

Version with integrated solenoid valve (Type 3738-20-xxx14xxxxx2xx)

Depending on the mounting platform used (ISO 228/1-G ¼ or ¼-18 NPT), customary fittings for metal or copper tubing or plastic hoses can be used.

Connections

The supply is connected at the side of the support element or mounting platform.

Operation with external solenoid valve (Type 3738-20xxx1000xxx200)

Connect the supply air to the external solenoid valve following the instructions given by the solenoid valve manufacturer.

6.3 Electrical connection

DANGER

Risk of fatal injury due to electric shock and/or the formation of an explosive atmosphere.

For electrical installation, observe the relevant electrotechnical regulations and the accident prevention regulations that apply in the country of use.

The following regulations apply to installation in hazardous areas: EN 60079-14 (VDE 0165, Part 1) **Explosive Atmospheres – Electrical Installations Design, Selection and Erection**.

The maximum permissible values specified in the EC type examination certificate apply when connecting the intrinsically safe circuits.

Adhere to the terminal assignment specified in the certificate. Switching the assignment of the electrical terminals may cause the explosion protection to become ineffective.

Electronic limit switch with intrinsically safe external solenoid valve:

The operating voltage and external solenoid valve are connected according to EN 60079-11, type of protection Ex i.

- **Ex i terminals: color: blue or black**

Electronic limit switch with non-intrinsically safe external solenoid valve:

The operating voltage and external solenoid valve are connected according to EN 60079-7, type of protection Ex e.

The following applies to external connection:

- **Ex i terminals: color: blue**
- **Ex e terminals: color: black**
- **Cable entry:** Ex e cable entry: black; Ex i cable entry: blue

The cable entries of the electronic limit switch with external **non-intrinsically safe** solenoid valve must be certified according to type of protection Ex e according to ATEX.

The degree of protection (IP grade) of the cable entries and the blanking plug must be the same as that of the limit switch.

Do not loosen enameled screws in or on the housing.

Note on the selection of cables and wires:

- Observe **clause 11.2** for installation of the **non-intrinsically safe** circuits and **clause 12 of EN 60079-14 (VDE 0165, Part 1)** for installation of the intrinsically safe circuits. Clause 12.2.2.7 of EN 60079-14 applies when running multi-core cables and wires with more than one intrinsically safe circuit.

- The radial thickness of the insulation of a conductor for common insulating materials (e.g. polyethylene) must not be smaller than 0.2 mm. The diameter of individual wires in a fine-stranded conductor must not be smaller than 0.1 mm. Protect the conductor ends against splicing, e.g. by using wire-end ferrules.
- When two separate cables are used for connection, an additional cable gland can be installed.
- Seal cable entries left unused with certified Ex e blanking plugs.

The electronic limit switch is powered over the connection of the contact A according to DIN EN 60947-5-6. **An additional electrical power supply is not required.**

The following function and terminal labeling apply to the contacts A and B:

	Port		Position
	+	–	
Contact A	41	42	Fail-safe position
Contact B	51	52	Operating position

Cable entry

The threaded connection for the terminal compartment is designed with an M20x1.5 thread.

The screw terminals are designed for wire cross-sections of 0.2 to 1.5 mm². Tighten by at least 0.5 Nm.

NOTICE

- The switching voltage of the integrated solenoid valve is connected either at the terminals V1 (81/82) or at the terminals V3 (81/82) (Type 3738-20xxx14xxxxx2xx). Only connect one pair of 81/82 terminals.
- Do not connect the switching voltage to the contacts A-St. Otherwise, the device will be damaged.

Note

When the integrated/external solenoid valve is correctly connected (24 V DC voltage applied), the LED for the solenoid valve is illuminated (see Fig. 12 and Fig. 13).

Connections

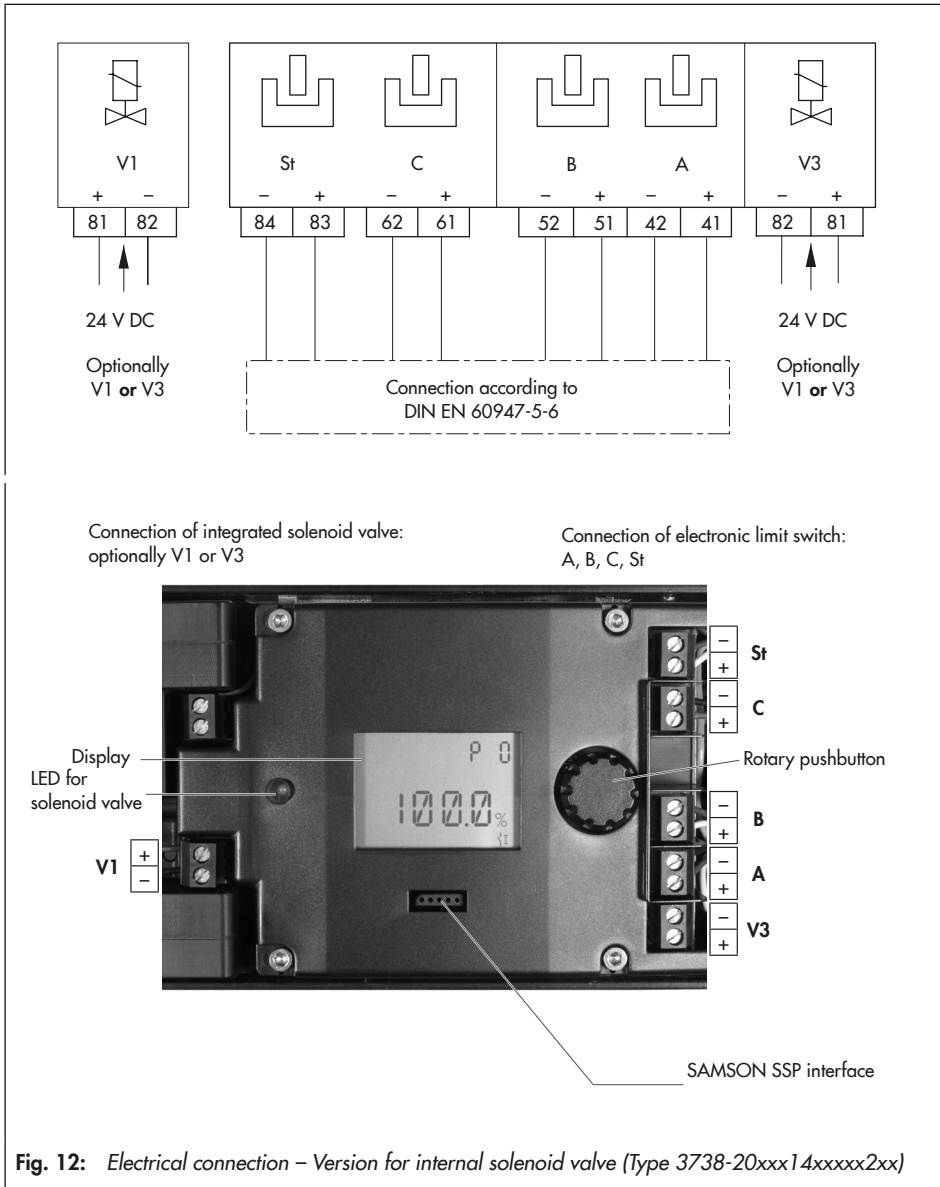

Fig. 12: Electrical connection – Version for internal solenoid valve (Type 3738-20xxx14xxxxx2xx)

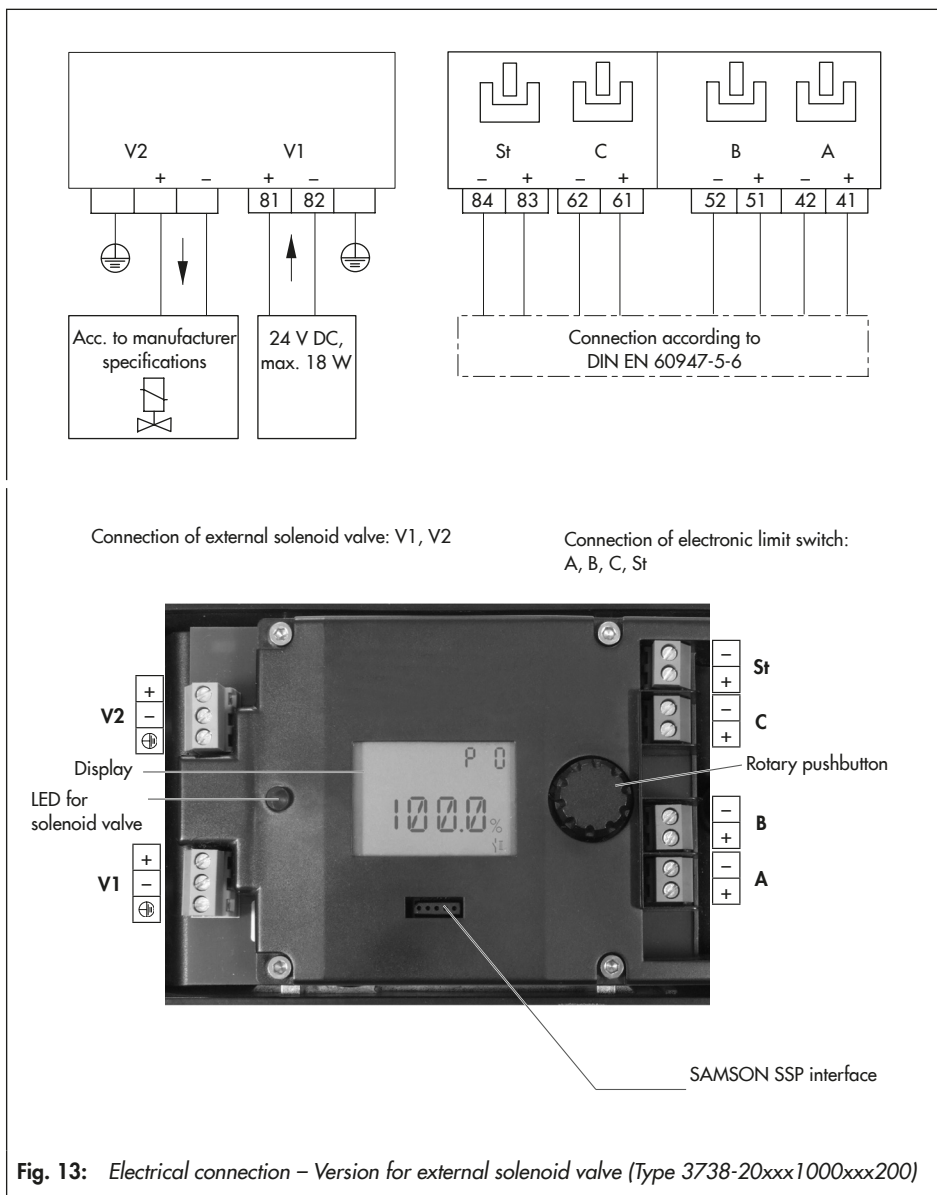

Fig. 13: Electrical connection – Version for external solenoid valve (Type 3738-20xxx1000xxx200)

7 Operating controls and readings

7.1 Rotary pushbutton

The rotary pushbutton (⊙) is located underneath the housing cover.

The device is operated on site using the rotary pushbutton:

Turn ⊙: Select parameters and values

Press ⊙: Confirm setting/exit parameter

7.2 SAMSON SSP interface

The SAMSON SSP interface is located underneath the housing cover.

The local SAMSON SSP interface of the electronic limit switch needs to be connected over a serial interface adapter cable (see Table 3 on page 28) to the RS-232 or USB port of the computer before the TROVIS-VIEW software can be used.

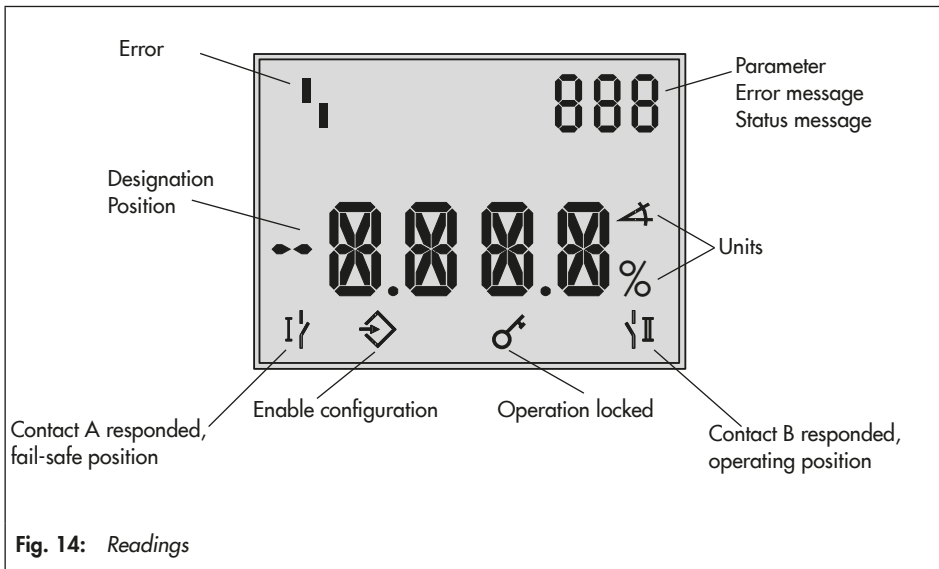

7.3 Operating structure

The P2 parameter allows the user to switch between the RUN operating mode and SET configuration mode. In the SET configuration mode, the parameters marked with an asterisk (*) (see section 1.3) can be changed and the device can be initialized.

To switch over modes, the key number must be entered first. The key number can be found on page 83. To avoid unauthorized use of the key number, remove the page or make the key number unreadable.

The **SET** configuration mode is indicated by the responding fault alarm contact St. In the display, the SET configuration mode is additionally indicated by the \diamond icon. If the device has not yet been initialized or it has been reset to its default settings (P21), the three contacts A, B and C also respond.

After the device has been initialized and is in RUN operating mode, various states of the contacts can be set (see Table 4) depending on the control and status or error messages. Parameters cannot be changed or, for example the device cannot be re-initialized in the RUN operating mode for reasons of safety.

Errors E0 to E8 have priority over the switching positions for reasons of safety. A serious device error E9 is additionally signalized by a wire breakage in accordance with DIN EN 60947-5-6.

Contact C can be used for monitoring the partial stroke test (PST). It responds when the valve position exceeds the selected limit ('PST step end' $\pm 1/2$ 'PST tolerance band' (P14 $\pm 1/2$ P15)). It is possible to monitor the PST target

range when the P12 parameter (status read-out for PST target range) is activated. In this case, the fault alarm contact St responds whenever the valve position is above or below the limit ('PST step end' $\pm 1/2$ 'PST tolerance band'). This monitoring function is not active by default.

If the partial stroke test is not used, a third switching position can be indicated by contact C.

The contacts can indicate the operating states listed in Table 4.

The operating structure is shown on the following pages in the form of schematic diagrams:

- Placing the electronic limit switch into operation using its default settings (page 37)
- Changing the operating mode and parameter settings (page 38)

Operating controls and readings

Table 4: Indication of operating states

Contacts A, B, C can configured as required (NC or NO contact) Contact St is always a NC contact				
A	B	C	St	
Possible operating states in SET configuration mode				
⊙	⊙	⊙	⊙	Device not initialized/default settings
⊙	○	⊙	⊙	Device initialized, fail-safe position
○	⊙	○	⊙	Device initialized, operating position
Possible operating states in RUN operating mode				
⊙	○	⊙	○	Fail-safe position
○	⊙	○	○	Operating position
⊙	○	⊙	⊙	Fail-safe position, F0 to F15 status messages or E8/E10 error message
○	⊙	○	⊙	Operating position, F0 to F15 status messages or E8/E10 error message
⊙	⊙	⊙	⊙	E0 to E7 error messages, F10 status message
⊠	⊗	⊠	⊠	Error E9 (serious device error)
Possible operating states during partial stroke test (PST), see section 9.2 for further details				
○	⊙/○	○	○	PST started, PST target range not reached yet
○	○	⊙ ¹⁾	○	PST target range reached
○	⊙	⊙ ¹⁾	○	PST successful
○	⊙	○	○	PST not completed successfully, P12 = NO
○	⊙	○	⊙	PST not completed successfully, P12 = YES

¹⁾ The contact remains activated three seconds after the valve moves out again of the PST target range.

○ NC = Closed; NO = Open (open: $I \leq 1.0$ mA, closed: $I \geq 2.2$ mA)

⊙ NC = Open; NO = Closed (open: $I \leq 1.0$ mA, closed: $I \geq 2.2$ mA)

⊗ Wire break, $I \leq 0.05$ mA

⊠ $I \leq 1.0$ mA

Placing the electronic limit switch into operation using its default settings – Switching voltage must be applied!

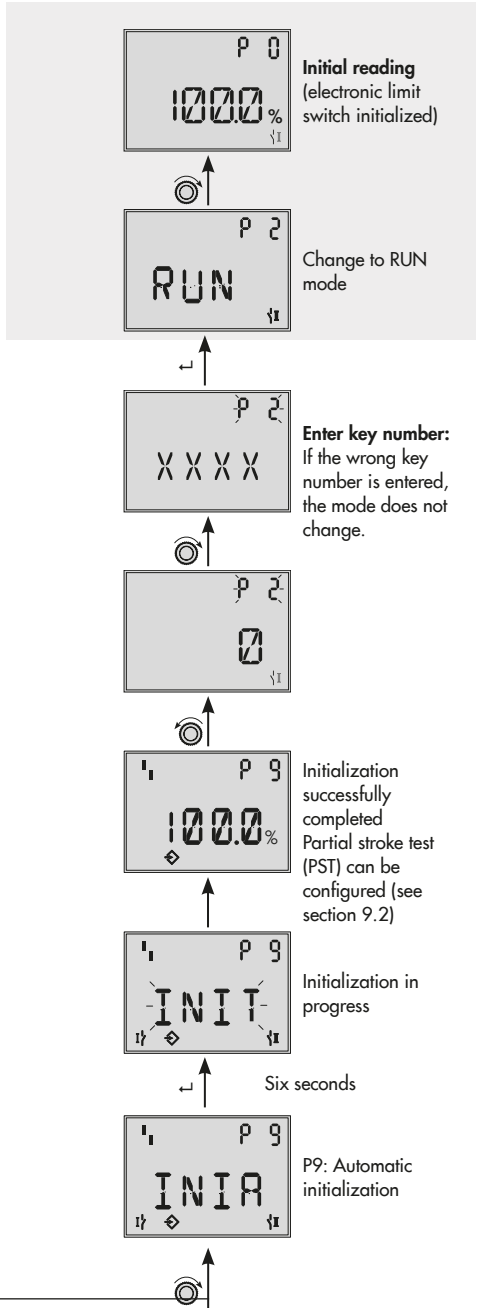
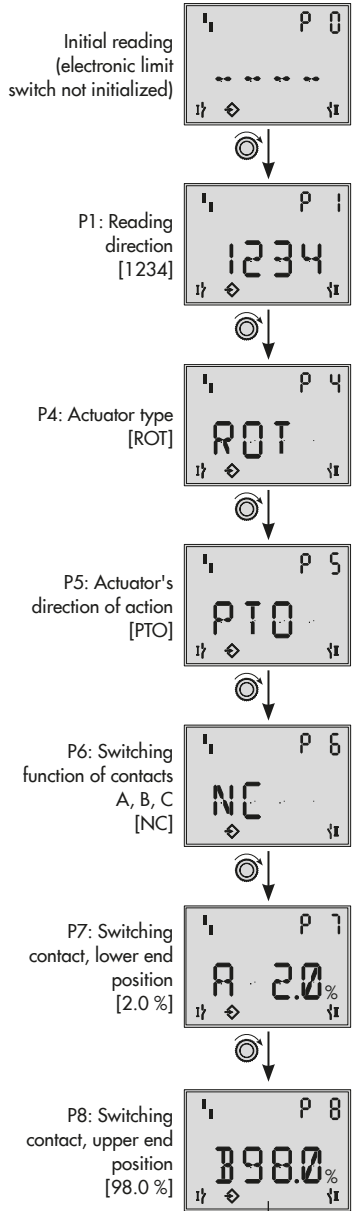

Gray background: RUN operating mode (operation, parameters cannot be changed)

⊙ : Turn ⊙ : Press ⊙

Changing the operating mode and parameter settings

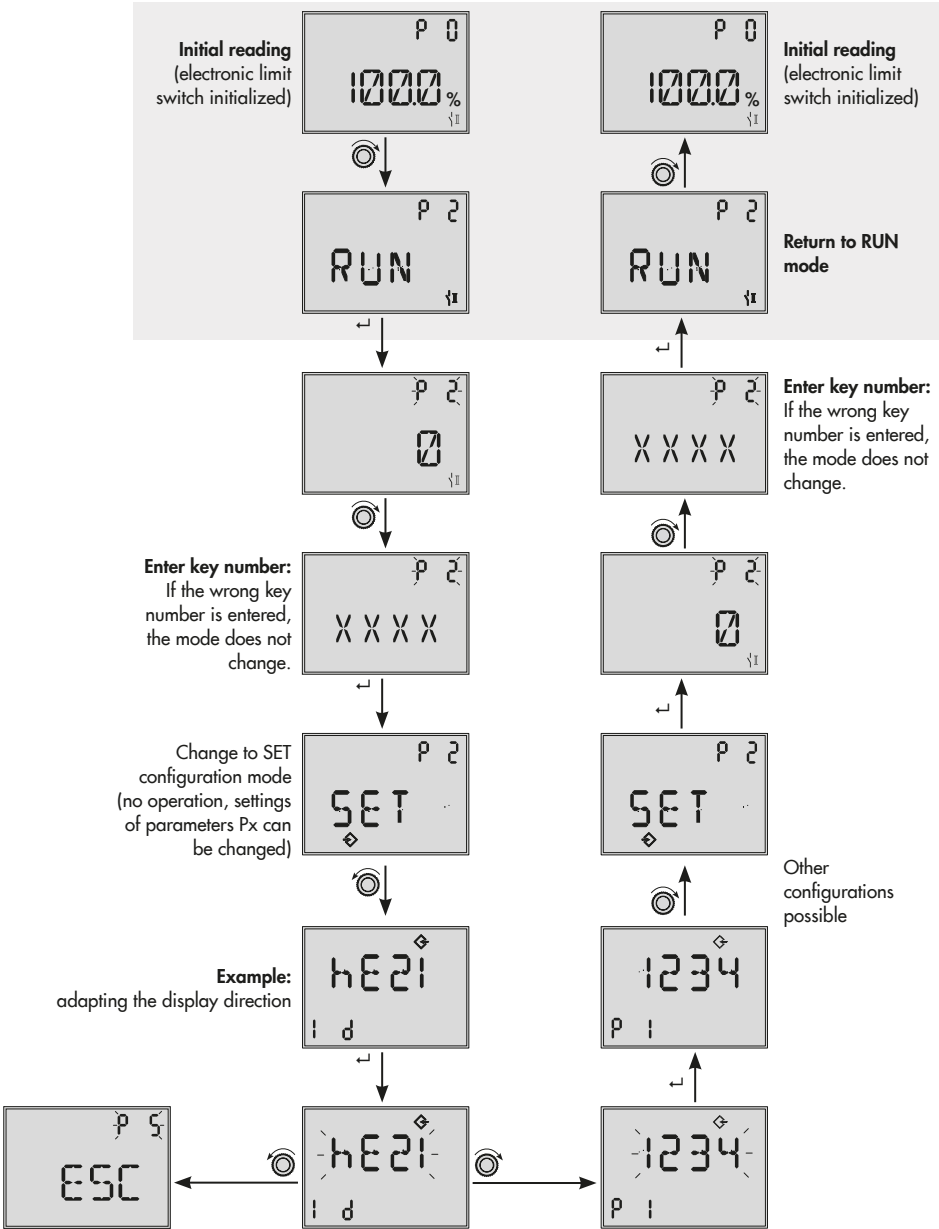

Gray background: RUN operating mode (operation, parameters cannot be changed)

8 Start-up

⚠ WARNING

Mount the electronic limit switch, keeping the following sequence:

- Mount the electronic limit switch on the actuator. See sections 5.1 and 5.2.
- Connect the supply air. See sections 6.1 and 6.2.
- Connect the electrical power. See section 6.3.
- Perform the start-up settings. See section 8.

📢 NOTICE

Perform the start-up settings in the same sequence as described (sections 8.1 to 8.7).

Reading after connecting the electrical power supply:



P0: Display when the electronic limit switch has not yet been initialized

- The **I1** fault alarm icon and **---** appear on the display **when the electronic limit switch has not yet been initialized**. The electronic limit switch is not in service. Parameter settings can be changed (P2 = SET). See page 38.

📌 Note

The current angle of rotation is set to 0° by pressing the rotary pushbutton (⊙).

- The current angle of rotation is displayed in % **when the electronic limit switch has been initialized**.
To change parameter settings, the configuration mode (**SET**) must be activated. See page 38.
The **F15** status message is activated in the configuration mode (**SET**).

8.1 Adapting the display direction

The reading on the electronic limit switch display can be turned by 180° to adapt it to the electronic limit switch's mounting situation.

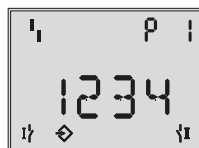

P1: Reading direction

If the displayed data appear upside down, proceed as follows:

Turn ⊙ → **P1**

Press ⊙, **P1** blinks

Turn ⊙ 1234/↕321

Press ⊙ to confirm the reading direction and to exit the parameter.

8.2 Verifying readings on display

NOTICE

For safety-instrumented systems, the display's functioning must be tested.

The display's functioning is checked using the P3 parameter.



P3: Display reading when the test has not been started



When the test has been started:
P3: Display reading 1



P3: Display reading 2

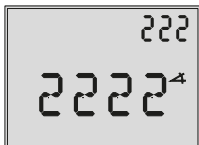

P3: Display reading 3

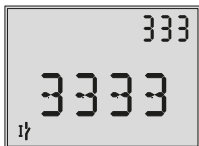

P3: Display reading 4

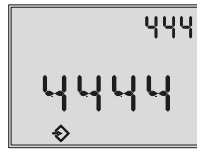

P3: Display reading 5

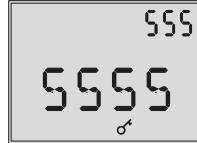

P3: Display reading 6



P3: Display reading 7

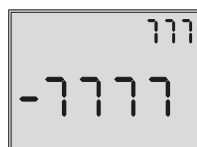

P3: Display reading 8

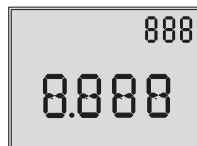

P3: Display reading 9

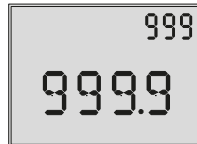

P3: Display reading 10

Turn → P3 (display: TSTD)

Press , reading 1

Turn , reading 2 to 10

Press to confirm testing. The last test of the display readings is saved with a time stamp in the electronic limit switch. The time stamp can be read in TROVIS-VIEW.

8.3 Determining the actuator type

The setting of the actuator type (rotary or linear actuator) is made using P4 parameter.

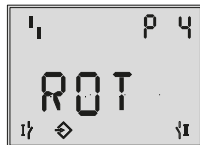

P4: Actuator type
Default: ROT

Turn \odot → **P4**

Press \odot , **P4** blinks

Turn \odot → ROT (rotary actuator)/LIN
(linear actuator)

Press \odot to confirm the actuator type and to exit the parameter.

i Note

After initialization, this parameter is locked and can first be selected and changed after performing a reset to default settings (P21).

8.4 Determining the direction of action

Observe the assignment of contacts A and B depending on the direction of action (page 83).

The setting is made using P5 parameter.



P5: Direction of action
Default: PTO

Turn \odot → **P5**

Press \odot , **P5** blinks

Turn \odot → **PTC** (power to close)/**PTO**
(power to open)

Press \odot to confirm direction of action and to exit the parameter.

i Note

After initialization, this parameter is locked and can first be selected and changed after performing a reset to default settings (P21).

8.5 Determining the switching function of contacts

The setting is made using P6 parameter.

i Note

The on-site operation allows the contacts A, B and C to be defined together as NO or NC contacts. The contacts can be configured separately in TROVIS-VIEW.

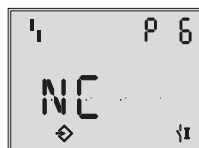

P6: Switching function of contacts A, B and C
Default: NC

Turn \odot → **P6**

Press \odot , **P6** blinks

Turn \odot → **NO/NC**

Press \odot to confirm switching function and to exit the parameter.

8.6 Adjusting the limit contacts

A limit signal is issued by the limit switches for fail-safe position (contact A) and for operating position (contact B). The contacts A and B can be adjusted within the range.

The switching response of the contacts can be adjusted within the actuator's travel range.

The switching responses of the contacts are set in the P7 (lower end position) and P8 (upper end position) parameters.

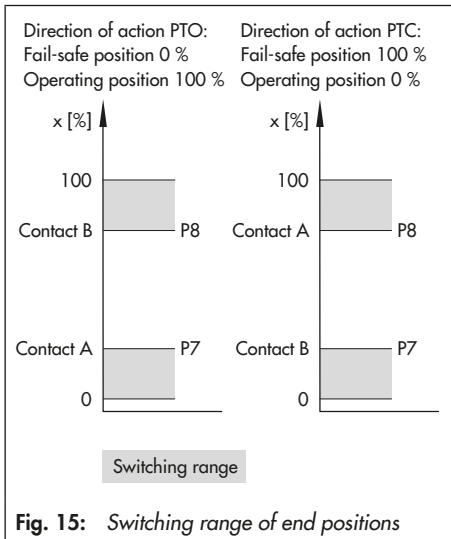

i Note

The following correlations apply to the setting ranges of the switching ranges for lower end position (P7) and the upper end position (P8):

- **P7**: 0.5 % to (P8 - 2.0 %)
- **P8**: (P7 + 2.0 %) to 99.5 %

Observe the assignment of contacts A and B depending on the direction of action (page 83).

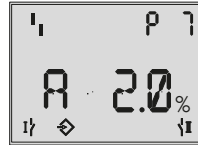

P7: Switching contact, lower end position
Default: 2.0 %
Example: Fail-safe position for PTO direction of action

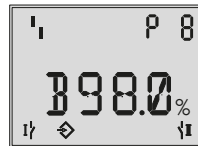

P8: Switching contact, upper end position
Default: 98.0 %
Example: Operating position for PTO direction of action

Turn \odot → **P7/P8**

Press \odot , **P7/P8** blinks

Turn \odot → Required switching value

Press \odot to confirm the switching value and to exit the parameter.

8.7 Initialization

⚠ WARNING

- *The initialization must only be started when the switching voltage is connected and the actuator is in the operating position.*
- *Check the control valve's max. permissible signal pressure before starting initialization.*
- *The actuator is moved through its entire travel range during initialization. Therefore, do not start initialization while a process is running, but only during start-up, when all shut-off valves are closed.*

NOTICE

After the electronic limit switch has been mounted onto another actuator or its mounting location has been changed and before re-initializing, the electronic limit switch needs to be reset to its default setting (Code P21). Refer to section 8.10).

Note

If an electronic limit switch is replaced with another electronic limit switch of the same type, the replaced electronic limit switch may not need to be re-initialized, provided certain conditions are met (see section 8.8).

After the electronic limit switch has been initialized, the current valve position appears in % on selecting P0. Keep the rotary pushbutton (⊙) pressed to display the reading as an angle (°).

Two types of initialization are available:

- Automatic initialization with P9 parameter
- Manual initialization with P10 parameter by manually confirming the end positions (POS1 and POS2)

8.7.1 Start automatic initialization

Note

The automatic initialization can be canceled by pressing the rotary pushbutton (⊙). ESC appears on the display.

Data saved in the electronic limit switch before the initialization can be restored by pressing the rotary pushbutton (⊙) again.



P9: Display reading when initialization has not been started

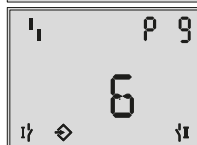

After initialization has started:
P9: Initialization is being prepared



P9: Initialization in progress

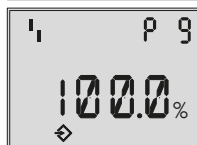

P9: Initialization successfully completed

Turn ⊙ → **P9** (display: INIA)

Press ⊙ and hold for six seconds. The seconds remaining until the initialization starts appear on the display.

Initialization starts (display: INIT): The valve moves twice from the operating position to the fail-safe position and back again to the operating position. It measures the travel between the end stops as well as the dead time and transit times for opening and closing the valve.

After the initialization has been successfully completed, the current valve position in % is indicated.

Start-up

The electronic limit switch is in the configuration mode (SET).

To start operation, exit the configuration mode (see page 38).

The automatic initialization is automatically canceled if a fault occurs (ERR on the display).

The initialization error can be read in the ERR parameter level:

- **E0:** No initialization
- **E1:** Actuator does not move
- **E2:** Min. travel not reached
- **E3:** Max. travel exceeded
- **E4:** Actuator travels too fast
- **E5:** No switching voltage applied
- **E6:** Time-out

8.7.2 Start manual initialization

i Note

- Select ESC on the display and press the rotary pushbutton to cancel the manual initialization. Data saved in the electronic limit switch before the initialization can be restored by pressing the rotary pushbutton (⊙) again.
- If the electronic limit switch was initialized manually, the partial stroke test cannot be started (see section 9.2).

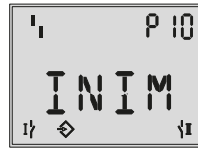

P10: Display reading when initialization has not been started



After initialization has started:
P10: Initialization is being prepared



P10: Confirmation of fail-safe position (solenoid valve de-energized)



P10: Fail-safe position found



P10: Confirmation of operating position (solenoid valve energized)

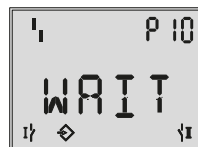

P10: Operating position found

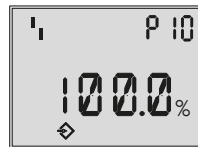

P10: Initialization successfully completed

Turn ⊙ → **P10** (display: INIM)

Press **⊙** and hold for six seconds. The seconds remaining until the position check starts appear on the display.

Display: POS1

➔ Move the valve to the fail-safe position manually (de-energize the solenoid valve).

Press **⊙** to confirm the fail-safe position →

WAIT

The electronic limit switch saves the fail-safe position.

Display: POS2

➔ Move the valve to the operating position manually (energize the solenoid valve).

Press **⊙** to confirm the operating position →

WAIT

The electronic limit switch saves the operating position.

After the initialization has been successfully completed, the current valve position in % is indicated.

The electronic limit switch is in the configuration mode (SET).

To start operation, exit the configuration mode (see page 38).

The manual initialization is automatically canceled if a fault occurs (ERR on the display).

The initialization error can be read in the ERR parameter level:

- **E0:** No initialization
- **E2:** Min. travel not reached
- **E3:** Max. travel exceeded
- **E6:** Time-out

8.8 Replacing an electronic limit switch

An (old) electronic limit switch can be replaced by another (new) electronic limit switch of the same type by performing an end position calibration in the operating or fail-safe position, but without having to initialize the new one, provided the following conditions are met:

- **Data from the electronic limit switch being replaced are downloaded and saved in TROVIS-VIEW.**
- **The screw with magnet must not be unfastened while the electronic limit switch is being replaced.**
- **The end stops of the valve must not be changed while the electronic limit switch is being replaced.**

Replacing an electronic limit switch

- ➔ Download and save data from the electronic limit switch being replaced in TROVIS-VIEW.
- ➔ Replace electronic limit switch.
- ➔ Load data from TROVIS-VIEW onto the new electronic limit switch.
- ➔ Perform an end position calibration as described in section 8.9.

8.9 Zero/end position calibration

When the zero point or end positions are incorrect, it may be necessary to recalibrate them. Always perform an end position calibration for the fail-safe position and for the operating position.

The electronic limit switch must be in the configuration mode (SET). See page 38.



P11: Reading when the end position calibration has not been started



After the end position calibration has been started:

P11: Zero/end position calibration in progress

Turn \odot → **P11** (display: REF)

Press \odot and hold for six seconds. The seconds remaining until the end position calibration starts appear on the display.

The current valve position is set to the travel stop (0 % or 100 %).

The electronic limit switch is in the configuration mode (SET).

To start operation, exit the configuration mode (see page 38).

The end position calibration is automatically canceled if an error occurs (ERR on the display).

The error can be read in the ERR parameter level:

- **E6:** Time-out
- **E8:** Unable to calibrate end positions

8.10 Reset to default settings

This function resets all parameters to the factory default settings (see parameter list in section 13). All error and status messages are also reset.

NOTICE

After performing a reset, the electronic limit switch needs to be re-initialized (see section 8.7).

The electronic limit switch must be in the configuration mode (SET). See page 38.



P21: Reset

Turn \odot → **P21** (RST)

Press \odot , **P21** blinks

Press \odot .

The initialization values are reset to the default settings.

→ Re-initialize the electronic limit switch (see section 8.7).

→ Set PST parameters (see section 9.2).

9 Operation

⚠ WARNING

The actuator shaft/stem moves while the electronic limit switch is operating.

Do not touch the actuator shaft/stem or obstruct it to avoid risk of injury to hands or fingers.

9.1 Lock operation

When the locking function is active, the electronic limit switch can only be operated remotely using the TROVIS-VIEW software. The locked on-site operation of the electronic limit switch is indicated on the display by the  icon.

The on-site operation is locked and unlocked in the TROVIS-VIEW software.

9.2 Partial stroke test (PST)

⚠ WARNING

Wear protection if the test is performed on the version with integrated solenoid valve while the housing cover is open.

The probability of failure on demand (PFD) can be reduced and maintenance intervals can be extended by the partial stroke test (PST).

This helps prevent the valve from seizing up in its operating position.

The following conditions must be met before the partial stroke test (PST) can be performed:

- An automatic initialization must have been performed (see section 8.7.1).
- The switching voltage must be applied.

Test procedure (Fig. 16)

The electronic limit switch issues pulses of various lengths to the solenoid valve (briefly de-energizing it) during the partial stroke test (PST), moving the valve further towards the fail-safe position.

The test has been completed successfully when the valve has reached the target range ('PST step end' \pm 1/2 'PST tolerance band') by one pulse, but not exceeded it. When the target range is reached, contact C responds

The analysis of a successfully completed test provides the following data:

- PST pulse length
- PST dead time
- PST transit time SV de-energized
- PST hold time
- PST transit time SV energized
- PST travel
- PST status

If the test could not be completed, the corresponding F8 or F9 status message is generated:

- **F8:** No switching voltage during PST
- **F9:** Time-out during PST

Start-up

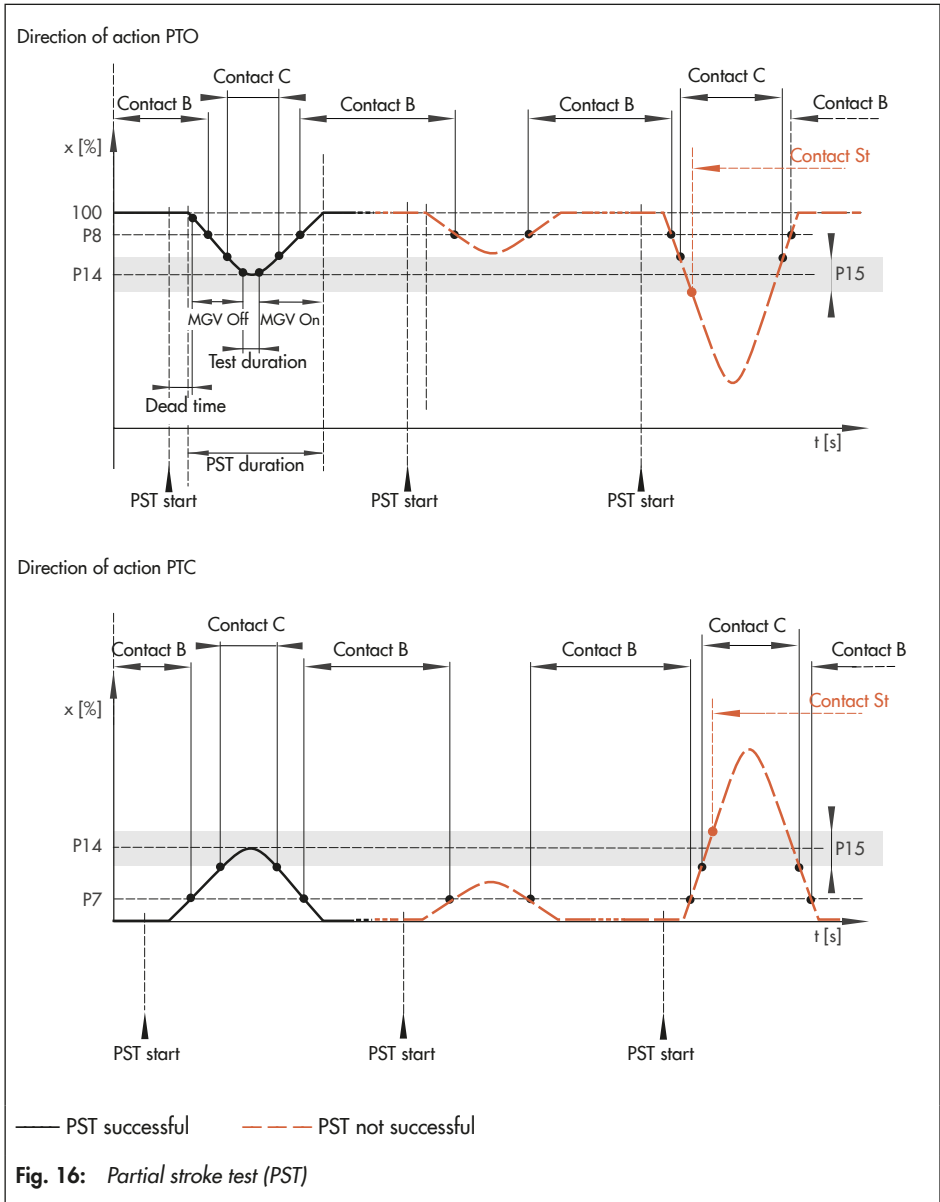

i Note

- If the travel of the PST is monitored and, if necessary, the status messages F6 ('Min. value for PST not reached') and F7 ('Max. value for PST exceeded') are to be generated, the P12 parameter must be set to YES.
- Contact C can be used to indicate a third switching position. Refer to following example for direction of action PTO.

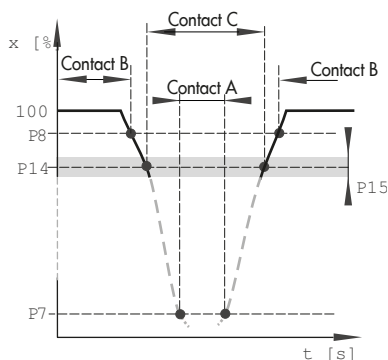

9.2.1 Defining the PST target range

Define the target range by configuring P14 and P15 parameters.

PST target range = 'PST step end' (P14) \pm 1/2 'PST tolerance band' (P15)

! NOTICE

It is important to take the process conditions (e.g. pressure, medium, dead time, break-away torque and torque of the valve) into account on defining the PST target range. A valve that opens (PTC) and closes (PTO) too far may affect the process.

The electronic limit switch must be in the configuration mode (SET). See page 38.

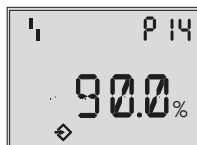

P14: PST step end
Default: 90.0 %

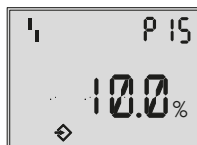

P15: PST tolerance band
Default: 10.0 %

Turn \odot \rightarrow **P14/P15**

Press \odot , **P14/P15** blinks

Turn \odot \rightarrow PST step end/PST tolerance band

Press \odot to confirm the value and to exit the parameter.

9.2.2 Starting the partial stroke test

A single PST test can be started manually or a regular PST test can be started automatically at defined time intervals.

Start PST automatically at defined intervals (RUN mode)

The test is performed automatically after a time interval (days) entered in P16 ('Automatic PST').

NOTICE

The automatic test causes the valve to leave its operating position without a switching demand.

Note

The default setting OFF causes the automatic test to be deactivated.

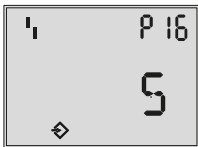

P16: Start automatic PST

Turn \odot → P16

Press \odot , P16 blinks

Turn \odot → Required time period [days]

Press \odot to confirm the entry and to exit the parameter.

Start PST manually (SET or RUN configuration mode)

A single test is started by the P17 parameter.



P17: Reading before the partial stroke test starts



After the partial stroke test starts:

P17: Start of PST is being prepared



P17: Test in progress

Turn \odot → P17 (PST)

Press \odot and hold for six seconds.

The seconds remaining until the test starts appear on the display.

The test starts (display: blinking PST).

Note

- A test in progress can be canceled by pressing the rotary pushbutton (\odot). ESC appears on the display.
- A canceled partial stroke test (PST) is logged with a time stamp in TROVIS-VIEW.

9.2.3 Example: PTO direction of action

The valve is normally open (operating position = 100 %). In the event of emergency, the valve is to close (fail-safe position = 0 %). The actuator's direction of action is therefore PTO (power to open), configured in the P5 parameter.

The upper end position (P8) is set at 98 %. This value is the same as the default setting. Contact B is activated when the valve moves beyond this value.

To prevent the valve seizing in the open position, a partial stroke test is to be performed on a weekly basis. During the partial stroke test, the valve is moved from the operating position towards the fail-safe position to a step end of 90 % by briefly de-energizing the solenoid valve. During the test, the valve must not move beyond a position of 85 % and a status message is activated for monitoring purposes if the PST target range is not reached or exceeded.

The following settings are made to the initialized electronic limit switch in the example while taking the process conditions into consideration:

1. Select configuration mode SET (P2)

The parameters required to configure the partial stroke test can only be set in the SET configuration mode (P2 = SET).

2. Define PST target range (P14, P15)

The PST target range is made up of the 'PST step end' (P14) and the 'PST tolerance band' (P15). The test has been successfully completed when the valve reached the position of the step end \pm half the step tolerance band, but not moved beyond it.

P14 ('PST step end') = 90 %

P15 ('PST tolerance band') = 10 %

→ PST target range = 90 % \pm 5 %
= 85 to 95 %

3. Activate the monitoring of the PST target range (P12)

The monitoring of the target range as well as the status readout F6 'Min. value for PST not reached' and F7 'Max. value for PST exceeded' are activated by the P12 parameter = YES.

When the status message F6 or F7 is generated, check the attachment, supply air lines and the valve. The setting for the target range might need to be adapted in the P14 and P15 parameters. See "Define PST target range (P14, P15)" in point 2.

4. Start automatic PST (P16)

P16 = 7 days

The test starts automatically once a week after switching to RUN operating mode.

The valve leaves the operating position (100 %) without a switching demand.

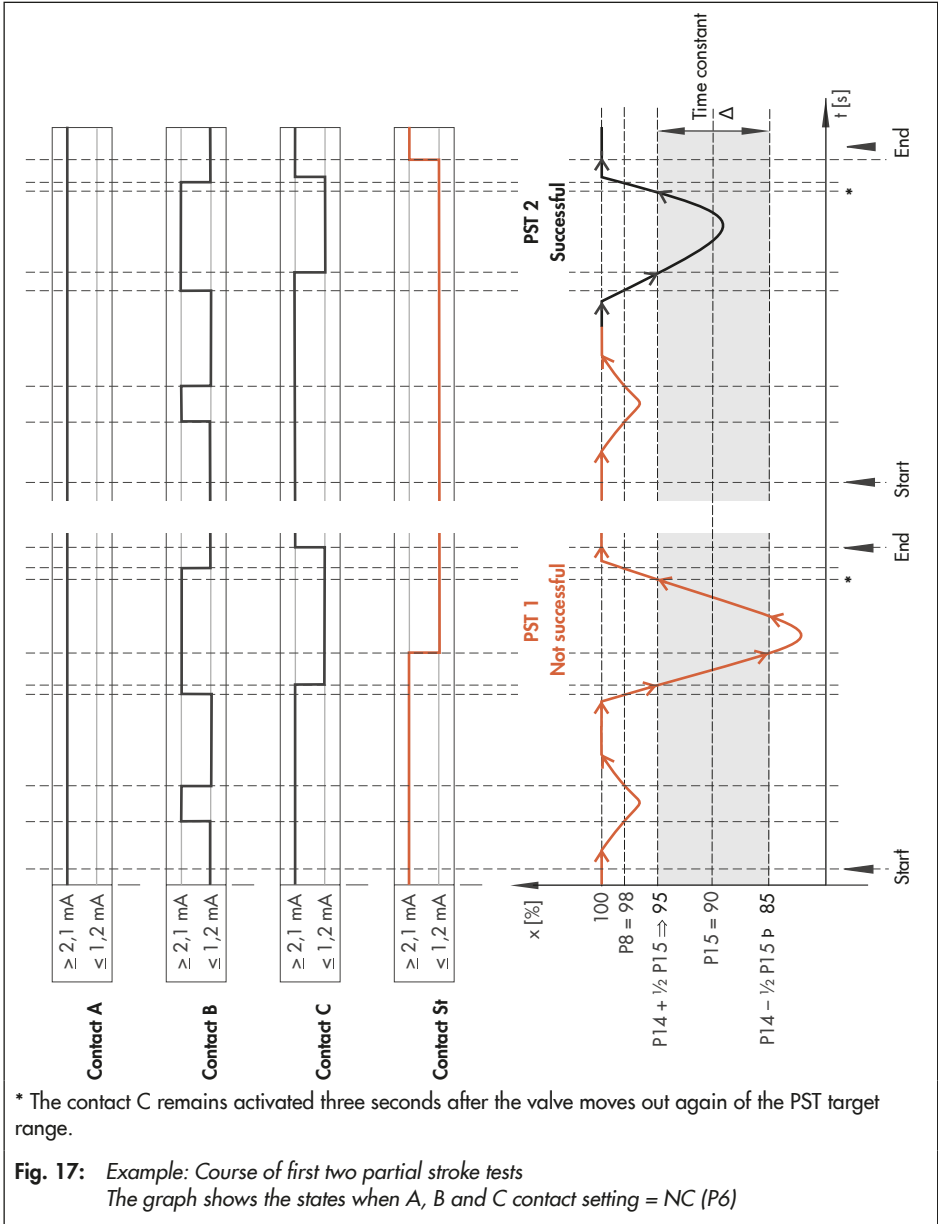

Fig. 17: Example: Course of first two partial stroke tests
The graph shows the states when A, B and C contact setting = NC (P6)

5. Select RUN operating mode (P2)

The countdown starts after the electronic limit switch has been switched to the RUN operating mode (P2 = RUN).

6. Evaluate PST (Fig. 17)

A partial stroke test is successfully completed when the valve reaches the defined PST target range, but has not moved beyond it. Contact C responds when the valve enters the PST target range and remains activated three seconds after the valve leaves the PST target range again.

The status contact St remains in the no response state (> 2.1 mA) as long as the PST target range is reached and not exceeded. If the status contact St is activated by the valve not reaching the PST target range, it remains activated until the next partial stroke test is started. This partial stroke test is then reevaluated.

The evaluation of the performed test provides the following data:

- PST pulse length
- PST dead time
- PST transit time SV de-energized
- PST hold time
- PST transit time SV energized
- PST travel
- PST status

Check the voltage supply and solenoid valve wiring when the status message F8 ('No switching voltage during PST') is generated.

Check the attachment and supply air line when the status message F9 ('Timeout during PST') is generated.

The last ten evaluations are saved in a non-volatile memory in the electronic limit switch and can be read in the TRO-VIS-VIEW software.

The solenoid valve is briefly de-energized by pulses issued by the electronic limit switch to close the valve.

In this example, the valve does not reach the PST target range during the first partial stroke test and moves beyond it. The test was not successfully completed. In the second automatic test, the valve initially does not reach the PST target range. The next step though ends in the PST target range, meaning the test has been successfully completed.

9.3 Testing the contacts

The following contacts can be tested in the **P19** parameter.

- **Contact A:** limit switch for fail-safe position
- **Contact B:** limit switch for operating position and simulation of wire break (B_LB parameter is displayed to meet requirements of DIN EN 60947-5-6)
- **Contact C:** indicates that the target range has been reached during the partial stroke test or that a third limit has been reached (see section 9.2).
- Contact St: Fault alarm contact

The electronic limit switch must be in the configuration mode (SET). See page 38.

Operation

Display when P6 = NC



P19: Reading before the test starts

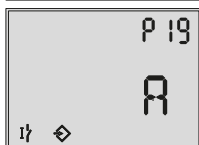

After the test has started:
P19: Simulation of contact A (limit switch for fail-safe position)

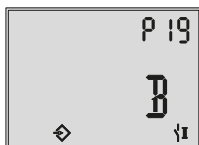

P19: Simulation of contact B (limit switch for operating position)

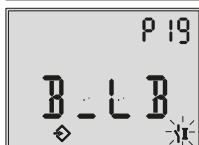

P19: Simulation of wire break at contact B

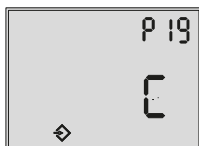

P19: Simulation of contact C: (signal on reaching target range during partial stroke test)



P19: Simulation of fault alarm contact

Turn \odot → **P19 (TSTC)**

Press \odot , **P19** blinks

Turn \odot → **A/B/B_LB/C/St**

All contacts are activated.

Press \odot .

The contact selected is deactivated while the rotary pushbutton is pressed.

Turn \odot → ESC

Press \odot to exit the parameter setting.

i Note

When P6 = NO, the logic for contacts A, B and C is reversed. B_LB on the display means the contact C is activated.

9.4 Testing the solenoid valve

You can de-energize the solenoid valve while the voltage is still applied using the P20 parameter. In this case, the valve moves to the fail-safe position.

Observe the assignment of contacts A and B depending on the direction of action (page 83).

The electronic limit switch must be in the configuration mode (SET). See page 38.

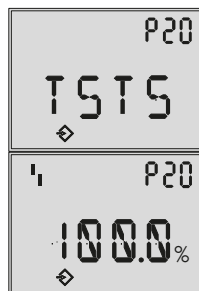

P20: Reading before the test starts

After the test has started:

P20: Testing solenoid valve

Example: PTO

Turn \odot → **P20 (TSTS)**

Press \odot , P20 blinks and ESC is displayed.

Turn \odot → Operating position

Press . The solenoid valve remains de-energized (the valve moves to the fail-safe position) as long as the rotary pushbutton is pressed.

Turn  → ESC

Press  to exit the parameter.

9.5 Malfunctions

9.5.1 Status messages

When a status message is generated, the  fault icon is displayed in the RUN operating mode. In addition, the fault alarm contact St is activated.

The possible cause of the error is indicated by the **STAT** parameter reading under **F0** to **F15**.

Note

- The status message **F4** ('Actuator transit time exceeded') is only generated when a fault occurs and when **P13** ≠ OFF.
- The status messages **F6** ('Min. value for PST not reached') and **F7** ('Max. value for PST exceeded') are only generated when a fault occurs and when **P12** = YES.
- The status message **F10** indicates that one of the error messages **E0** to **E10** has been generated.



Example:

F2: Limit of maximum rotary motion (P26) exceeded

Refer to the parameter list (section 13.1) for possible causes and the recommended action.

9.5.2 Error messages

When an error message is generated, the  fault icon is displayed in the **RUN** operating mode.

The possible cause of the error is indicated by the **ERR** parameter reading under **E0** to **E10**.

If an error **E0** to **E8** exists, all contacts (A, B, C and St) respond for reasons of safety. Error **E9** (device error 1) causes a wire break (contacts A, C, St: $I \leq 1.0$ mA, contact: $I \leq 50.0$ mA) to be additionally signaled to meet requirements of DIN EN 60947-5-6. Error **E10** (device error 2) causes the switching position to be displayed unchanged.



Example:

E0: No initialization

Refer to the parameter list (section 13.1 and section 13.2) for possible causes and the recommended action.

9.5.3 Confirming status and error messages

Note

The status messages **F0**, **F1**, **F3** and **F10** as well as the error message **E0** cannot be confirmed.

Maintenance, calibration and work on equipment

The electronic limit switch must be in the configuration mode (SET). See page 38.

Turn  → **F0/.../F10, STAT** or **E0/.../E10, ERR**

Press , **F0/.../F10, E1/.../E10** blinks

Turn  → **RST**

Press  to confirm status/error message.

10 Maintenance, calibration and work on equipment

Interconnection with intrinsically safe circuits to check or calibrate the equipment inside or outside hazardous areas must be performed only with intrinsically safe current/voltage calibrators and measuring instruments to rule out any damage to components relevant to explosion protection.

Observe the maximum permissible values specified in the certificates for intrinsically safe circuits.

10.1 Servicing

The electronic limit switch does not require any maintenance when used for its intended purpose.

DANGER

Risk of electrostatic charging

Due to the high surface resistance of the enclosure cover ($R_{isol} \geq 10^9 \Omega$), installation and maintenance on the equipment must be performed in such a way as to prevent electrostatic charging.

Version with integrated solenoid valve (Type 3738-20-xxx14xxxxx2xx)

There are filters with a 100 μm mesh size in the pneumatic connections for supply and output which can be removed and cleaned, if required.

The maintenance instructions of any upstream supply air pressure reducing stations must be observed.

11 Servicing explosion-protected devices

If a part of the device on which the explosion protection is based needs to be serviced, the device must not be put back into operation until a qualified inspector has assessed it according to explosion protection requirements, has issued an inspection certificate or given the device a mark of conformity.

Inspection by a qualified inspector is not required if the manufacturer performs a routine test on the device before putting it back into operation and the passing of the routine test is documented by attaching a mark of conformity to the device.

Replace explosion-protected components only with original, routine-tested components by the manufacturer.

Devices that have already been used outside hazardous areas and are intended for future use inside hazardous areas must comply with the safety requirements placed on serviced devices. Before being operated inside hazardous areas, test the devices according to the specifications for servicing explosion-protected devices.

12 Firmware update (serial interface)

Firmware updates on electronic limit switches currently in operation can be performed as follows:

When updates are performed by a service employee appointed by SAMSON, the update is confirmed on the device by the test mark assigned by SAMSON's Quality Assurance.

In all other cases, only plant operator personnel with written approval may perform updates. Updates are to be confirmed on the device by approved personnel.

Laptops and computers connected to the power supply must not be used without an additional protective circuit.

This does not apply to laptop computers in battery operation. In this case, it is assumed that a battery-powered laptop computer runs briefly for software programming or testing purposes.

a) Updates outside the hazardous area:

The electronic limit switches must be removed from the actuator. Update them outside the hazardous area.

b) Updates on site:

Updates on site are only permitted after the plant operator presented a signed hot work permit.

After updating has been completed, add the current firmware to the nameplate; this can be done using labels.

13 Disposal



SAMSON is a producer registered at the following European institution ► <https://www.ewrn.org/national-registers/national-registers>.
WEEE reg. no.:
DE 62194439/FR 025665

- ➔ Observe local, national and international refuse regulations.
- ➔ Do not dispose of components, lubricants and hazardous substances together with your other household waste.



i Note

We can provide you with a recycling passport according to PAS 1049 on request. Simply e-mail us at aftersaleservice@samsongroup.com giving details of your company address.

💡 Tip

On request, we can appoint a service provider to dismantle and recycle the product as part of a distributor take-back scheme.

14 Parameter list

No.	Parameter – Readings, values [default setting]	Description
Parameters marked with an asterisk (*) can only be changed when the electronic limit switch is in the SET configuration mode (set in P2).		
P0	Info: actual value	After initialization: current valve position in % Keep  pressed down → current valve position in ° (angle) Before initialization: Travel in °
P1	Reading direction 1234 · ∅ZL · ESC	The reading direction of the display is turned by 180°.
Start-up		
P2	Configuration RUN · [SET] · ESC	RUN: Operation mode, parameter settings cannot be changed SET: Configuration mode (no operation), parameter settings can be changed,  ,  icons, F15 status message generated
P3	Verify LCD segments TSTD, 0000 to 9999	Read only
P4*	Actuator type [ROT] · LIN · ESC Note: After initialization, this parameter is locked and cannot be selected and changed to the default settings until after performing a reset (P21).	ROT: Rotary actuator LIN: Linear actuator
P5*	Actuator's direction of action [PTO] · PTC · ESC Note: Observe the assignment depending on the direction of action (see page 83). After initialization, this parameter is locked and cannot be selected and changed to the default settings until after performing a reset (P21).	PTO (power to open): Fail-safe position = Valve CLOSED, 0 % of travel range Operating position = Valve OPEN, 100 % of travel range PTC (power to close): Fail-safe position = Valve OPEN, 100 % of travel range Operating position = Valve CLOSED, 0 % of travel range

No.	Parameter – Readings, values [default setting]	Description	
P6	Switching function of contacts A, B, C [NC] · NO NX1 ... NX6 ESC Note: The contacts A, B and C can be individually configured in the TRO-VIS-VIEW software. This indicated on the display as NX1 ... NX6. All the contacts are configured together as NC contact (1) or NO contact (2) by the on-site operation.	NC contact NO contact	See section 8.5.
P7*	Switching contact, lower end position 0.5 % to (P8 – 2.0 %) · ESC [2.0 %] Note: Observe the assignment depending on the direction of action (see page 83).	The following applies: PTO → Switching contact for fail-safe position PTC → Switching contact for operating position	See section 8.6.
P8*	Switching contact, upper end position (P7 + 2.0 %) to 99.5 % · ESC [98.0 %] Note: Observe the assignment depending on the direction of action (see page 83).	The following applies: PTO → Switching contact for operating position PTC → Switching contact for fail-safe position	See section 8.6.
P9*	Automatic initialization (INIA)	Starts initialization	See section 8.7.1.
P10*	Manual initialization (INIM)	Initialization after manual confirmation of fail-safe position (POS1) and operating position (POS2)	See section 8.7.2.
P11*	End position calibration (REF)	A calibration at the current position is performed.	See section 8.9.
Status readout			
P12*	Issue status PST target range YES · [NO] · ESC	Issue status message F6/F7 if the valve moves to a position outside the PST target range ('PST step end' ± ½ 'PST tolerance band').	See section 9.2.
P13*	Status indication actuator transit time [OFF] · 0.5 to 1800.0 s · ESC	Issue status message F4 when the control valve exceeded the adjusted actuator transit time.	See section 9.5.1.

Parameter list

No.	Parameter – Readings, values [default setting]	Description	
Partial stroke test (PST)			
The PST step range is limited between 2 and 98 % ('PST step end' \pm $\frac{1}{2}$ 'PST tolerance band')			
P14*	PST step end 4.0 to 96.0 % · ESC [90.0 %]	Step end position that the valve is to be moved to during the PST. If the partial stroke test is not used, a third switching position can be indicated by contact C.	See section 9.2.
P15*	PST tolerance band 4.0 to 96.0 % · ESC [10.0 %]	Tolerance added to the PST step end position. The partial stroke test has been completed successfully when the valve has reached the target range ('PST step end' \pm $\frac{1}{2}$ 'PST tolerance band') by one pulse, but not exceeded it.	See section 9.2.
P16*	Start automatic PST [OFF] · 1 to 999 days · ESC	Interval between automatic partial stroke tests	See section 9.2.
P17	Start manual PST (PST)	A single automatic partial stroke test is started.	See section 9.2.
Locking function			
P18*	Lock operation [NO] · SSP · HMI · ESC	HMI: Locking of on-site operation (icon: ) Only using TROVIS-VIEW! SSP: Locking of remote operation in TROVIS-VIEW. Only with on-site operation!	See section 9.1.
Test functions			
P19*	Testing contacts TSTC, A, B, B_LB, C, St ESC Note: B_LB on the display simulates a wire break according to NAMUR at contact B.	Checking of contacts A, B, C and St	See section 9.3.
P20*	Testing solenoid valve (TSTS)	Solenoid valve de-energized (fail-safe position)	See section 9.4.
Reset function			
P21*	Reset RST · ESC	Resets all settings of electronic limit switch to the factory default settings.	See section 8.10.

No.	Parameter – Readings, values [default setting]	Description	
Display functions · Read only			
P22	Note: Actuator transit time when solenoid valve is de-energized	Time [s] required by the actuator to move to the fail-safe position (dead time + transit time) Values determined during automatic initialization (P9)	–
P23	Info: actuator transit time when solenoid valve is energized	Time [s] required by the actuator to move to the operating position (dead time + transit time) Values determined during automatic initialization (P9)	–
P24	Info: temperature	Current operating temperature [°C] inside the electronic limit switch Keep  pressed down → reading in °F	–
P25	Info: operating hours	Number of operating hours	–
Rotary motion			
P26*	Max. rotary motions OFF · 100 to 9.9E7 · ESC [1.0E4] Note: The monitoring of the rotary motions is deactivated by P26 = OFF.	Status message F2 is generated when the max. number of rotary motions has been reached.	–
P27*	Reset rotary motion counter RST · ESC	The unopened parameter indicates the number of rotary motions from one end position to the other. To reset the counter, open the parameter, select RST and confirm.	–
Firmware version			
P28	Info: firmware version	Current firmware version	–

14.1 Status messages

No.	Status message	Possible causes
Status messages marked with an asterisk (*) can be confirmed in SET configuration mode. See section 9.5.1.		
TROVIS-VIEW: Current status messages are saved with a time stamp in [Diagnostics – Status messages].		
F0	Stationary outside required/desired end positions	<ul style="list-style-type: none"> • Mechanical blockage • Supply pressure too low • External leakage Recommended action <ul style="list-style-type: none"> • Check attachment and supply air line.
F1	Left end position without being required to move	<ul style="list-style-type: none"> • Incorrect voltage supplied to the solenoid valve • Supply pressure too low • External leakage Recommended action <ul style="list-style-type: none"> • Check switching voltage to integrated/external solenoid valve. • Check supply air line.
F2	Limit of maximum rotary motion (P26) exceeded	The value entered in P26 for the maximum rotary motion has been exceeded. Recommended action <ul style="list-style-type: none"> • Deactivate function or enter higher value.
F3	Temperature limits exceeded	The temperature in the electronic limit switch is too low/too high. Recommended action <ul style="list-style-type: none"> • Check the operating conditions.
F4*	Actuator transit time exceeded	The actuator transit time has exceeded the limit entered in P13. Recommended action <ul style="list-style-type: none"> • Check attachment. • Enter a higher limit. <p>Note: The status message is only generated when P13 ≠ OFF.</p>
F5*	Actuator stationary when required to move	<ul style="list-style-type: none"> • Mechanical blockage • Supply pressure too low • External leakage Recommended action <ul style="list-style-type: none"> • Check attachment and supply air line. <p>Note: If the valve moves after a delay, F5 remains active until the next successful switching demand.</p>

No.	Status message	Possible causes
Partial stroke test (PST)		
F6* F7*	Min. value for PST not reached Max. value for PST exceeded	<ul style="list-style-type: none"> • Mechanical blockage • Friction too high • Supply pressure too low Recommended action <ul style="list-style-type: none"> • Check attachment and supply air line. • Check valve.
Note: The status messages are only generated when P12 = YES.		
F8*	No switching voltage during PST	<ul style="list-style-type: none"> • Incorrect voltage supplied to the solenoid valve • Breakage of wire to external solenoid valve Recommended action <ul style="list-style-type: none"> • Check switching voltage to integrated/external solenoid valve.
Note: It is only evaluated when the partial stroke test is started manually (P17).		
F9*	Time-out during PST	<ul style="list-style-type: none"> • Mechanical blockage • Supply pressure too low • External leakage Recommended action <ul style="list-style-type: none"> • Check attachment and supply air line.
F10	Error E0 to E10 exists	See section 13.2
F15	Configuration mode SET activated	See page 39

14.2 Error messages

No.	Error message	Possible causes
Error messages marked with an asterisk (*) can be confirmed in SET configuration mode. See section 9.5.2.		
TROVIS-VIEW: The last 32 error messages are displayed with a time stamp in [Diagnostics – Logging of device errors].		
E0	Device not initialized	<ul style="list-style-type: none"> The electronic limit switch has not yet been initialized. Recommended action <ul style="list-style-type: none"> Start initialization with P9 or P10 parameter.
E1*	INIT: actuator does not move	<ul style="list-style-type: none"> Mechanical blockage Supply pressure too low External leakage Incorrect voltage supplied to the solenoid valve Recommended action <ul style="list-style-type: none"> Check attachment and supply air line. Check switching voltage to integrated/external solenoid valve.
E2*	INIT: min. travel not reached	<ul style="list-style-type: none"> Mechanical blockage Supply pressure too low External leakage Recommended action <ul style="list-style-type: none"> Check attachment and supply air line. Increase angle of rotation at the actuator.
E3*	INIT: max. travel exceeded	<ul style="list-style-type: none"> Maximum angle exceeds 170°. Recommended action <ul style="list-style-type: none"> Reduce angle of rotation at the actuator.
E4*	INIT: actuator travels too fast	<ul style="list-style-type: none"> K_V coefficient of solenoid valve too high Recommended action <ul style="list-style-type: none"> Install a restriction. Version for external solenoid valve: Reduce K_V coefficient at solenoid valve.
E5*	INIT: no switching voltage applied	<ul style="list-style-type: none"> Incorrect voltage supplied to the solenoid valve Forced venting active during initialization Recommended action <ul style="list-style-type: none"> Check switching voltage to integrated/external solenoid valve. Check forced venting input.

No.	Error message	Possible causes
E6*	INIT: time-out	<ul style="list-style-type: none"> • Supply pressure too low • Friction too high • K_V coefficient of solenoid valve too low Recommended action <ul style="list-style-type: none"> • Check attachment and supply air line. • Version for external solenoid valve: Use a different solenoid valve with a higher K_V coefficient.
E7*	Function canceled	<ul style="list-style-type: none"> • Internal error Recommended action <ul style="list-style-type: none"> • Repeat function/initialization.
E8*	Unable to calibrate end positions	<ul style="list-style-type: none"> • The end stops have shifted by 10° at the minimum. Recommended action <ul style="list-style-type: none"> • Re-initialize the electronic limit switch.
Device error		
E9*	Device error 1	<ul style="list-style-type: none"> • Internal error Recommended action <ul style="list-style-type: none"> • Restart the electronic limit switch (return it to SAMSON if error repeatedly occurs). <p>Note: When E9 is generated, the wire break (contact B_LB) is additionally signaled in accordance with DIN EN 60947-5-6.</p>
E10*	Device error 2	<ul style="list-style-type: none"> • Internal error Recommended action <ul style="list-style-type: none"> • The electronic limit switch should be replaced soon. The device still functions.

15 Dimensions in mm

Dimensions for attachment to rotary actuators according to VDI/VDE 3845 using a mounting platform

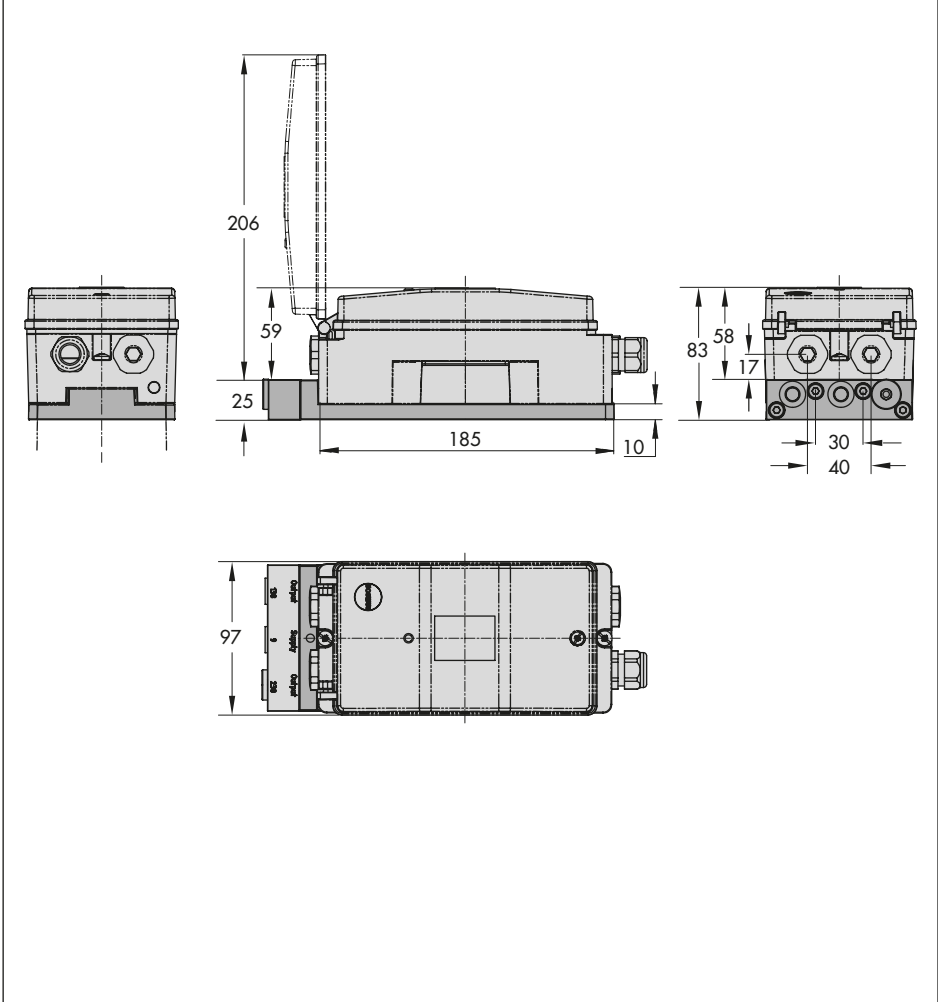

Attachment to PFEIFFER Type 31a Actuator (Edition 2020+)

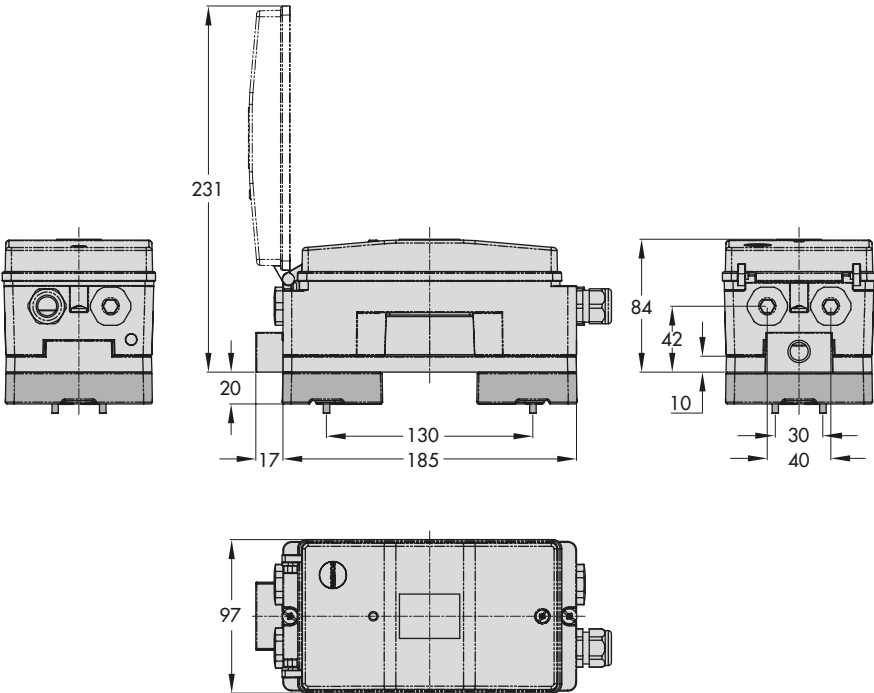

Attachment to linear actuators according to IEC 60534-6 (NAMUR)

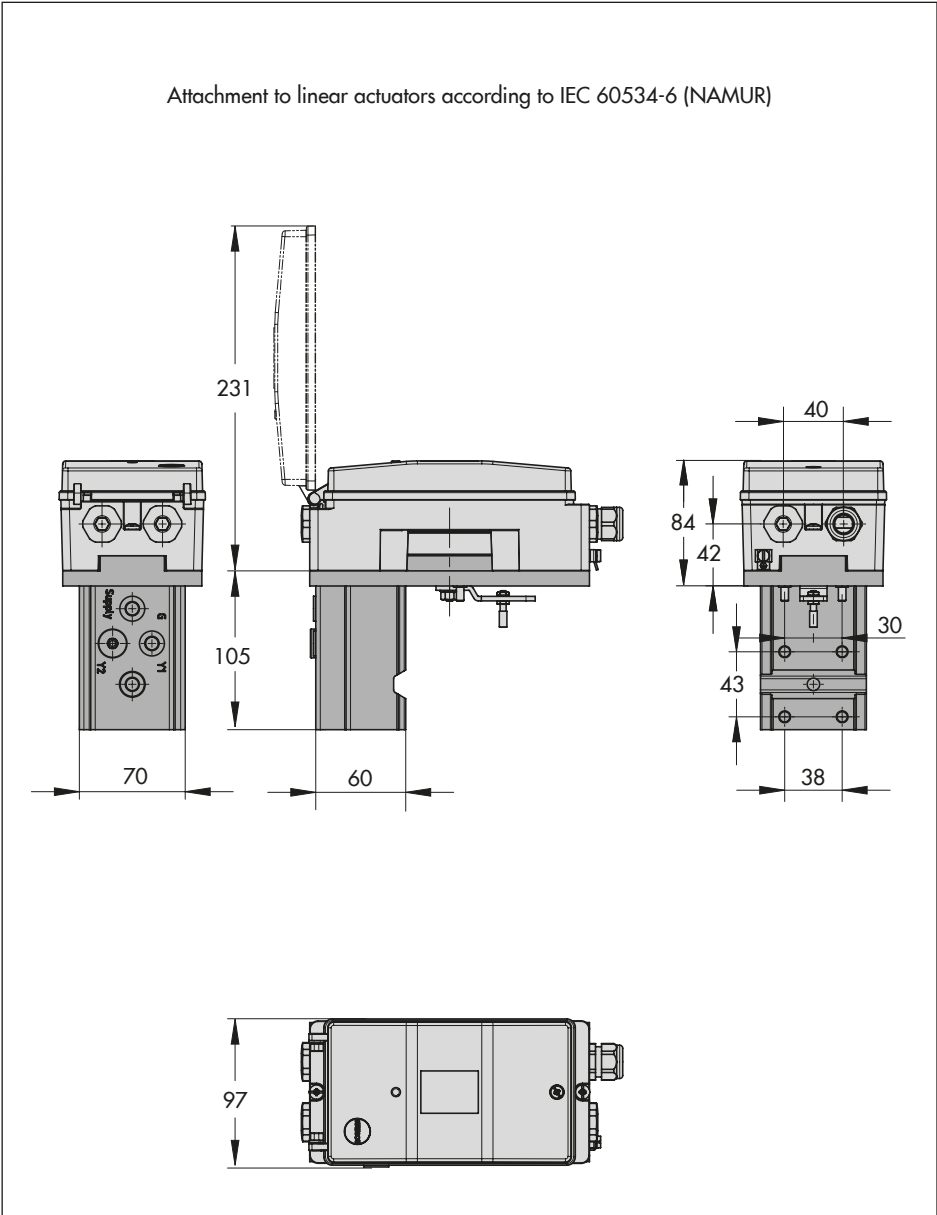

15.1 Fixing levels according to VDI/VDE 3845 (September 2010)

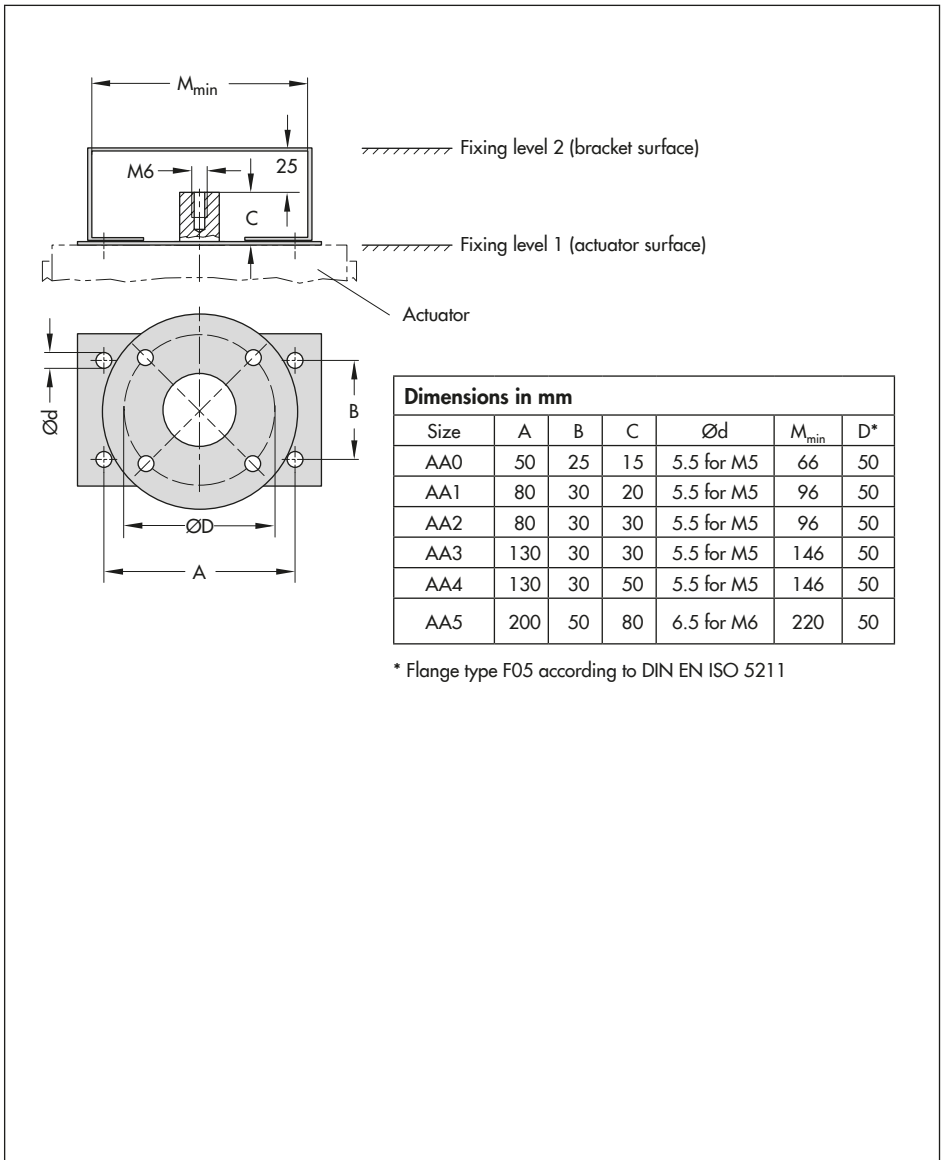



EC Type Examination Certificate

(1) Equipment and Protective Systems Intended for Use in Potentially Explosive Atmospheres – Directive 94/9/EC

(2) EC type examination certificate number

(3) **PTB 08 ATEX 2039 X**

(4) Equipment: Type 3738...-110... Electronic Valve Position Monitor

(5) Manufacturer: SAMSON AG Mess- und Regeltechnik

(6) Address: Weismüllerstraße 3, 60314 Frankfurt am Main, Germany

(7) This equipment and any acceptable variation thereto are specified in the schedule to this certificate and the documents therein referred to.

(8) Physikalisch-Technische Bundesanstalt, notified body no. 0102 in accordance with Article 9 of the Council Directive 94/9/EC of 23 March 1994, certifies that this equipment has been found to comply with the essential health and safety requirements relating to the design and construction of equipment and protective systems intended for use in potentially explosive atmospheres, given in Annex II to the Directive. The examination and test results are recorded in the confidential Assessment and Test Report **PTB Ex 09-28163**.

(9) Compliance with the essential health and safety requirements has been assured by compliance with:

EN 60079-0:2006 **EN 61241-0:2006**
EN 60079-11:2007 **EN 61241-11:2006**

(10) If the sign "X" is placed after the certificate number, it indicates that the equipment is subject to special conditions for safe use specified in the schedule to this certificate.

(11) This EC type examination certificate relates only to the design and construction of the specified equipment or protective system in accordance with Directive 94/9/EC. Further requirements of this Directive apply to the manufacture and supply of this equipment. These requirements are not covered by this certificate.



(12) The marking of the equipment shall include the following:

 II 2G Ex Ia IIC T6 or II 2D Ex Ia IAD A21 IP66 T90 °C

Certification Sector for Explosion Protection Braunschweig, 16 March 2009
O/O
[Signature Johannsmeyer, stamp: Physikalisch-Technische Bundesanstalt 56]
Dr.-Ing. U. Johannsmeyer
Director and Professor



[Translation of German original]
 Physikalisch-Technische Bundesanstalt
 Braunschweig and Berlin

(13) **Enclosure**

(14) **EC Type Examination Certificate PTB 08 ATEX 2039 X**

(15) **Description of the equipment or protective system:**

The Type 3738...110... Electronic Valve Position Monitor is designed to safely indicate the end positions of on/off control valves and includes different diagnostic functions for safe valve operation. The valve monitor in type of protection Ex ia IIC is used for connection to intrinsically safe NAMUR contacts with intrinsically safe internal or external solenoid valves.

The valve monitor is intended for use in hazardous areas.
 The following table lists the relation between equipment type, type of protection, temperature class and permissible ambient temperature range:

Type	Type of protection	Temperature class	Permissible ambient temperature range
3738...110...	Ex ia IIC	T6	-40 °C to 55 °C
		T5	-40 °C to 70 °C
		T4	-40 °C to 80 °C

Electric data

Supply current circuit using limit switch (A) NAMUR contact in type of protection Ex ia IIC (terminals 41/42)
 For connection to a certified intrinsically safe current circuit only

Max. values:
 U_i = 20 V
 I_i = 60 mA
 P_i = 400 mW
 L_i negligibly small
 C_i = 5 nF

Limit switches (B/C) NAMUR contact in type of protection Ex ia IIC (terminals 51/62 or 61/62)
 For connection to a certified intrinsically safe current circuit only

Max. values:
 U_i = 20 V
 I_i = 60 mA
 P_i = 400 mW
 L_i negligibly small
 C_i = 15 nF

EC type examination certificate without signature not valid as issued.
 This EC type examination certificate may only be reproduced without changes.
 Exempts or modifications are to be approved by Physikalisch-Technische Bundesanstalt.
 Physikalisch-Technische Bundesanstalt - Bundesallee 100 - 38116 Braunschweig, Germany
 PTB-3738.doc

[Translation of German original]
 Physikalisch-Technische Bundesanstalt
 Braunschweig and Berlin

Schedule to the EC Type Examination Certificate PTB 08 ATEX 2039 X

Limit switch (status) in type of protection Ex ia IIC
 For connection to a certified intrinsically safe current circuit only

Max. values:
 U_i = 20 V
 I_i = 60 mA
 P_i = 400 mW
 L_i negligibly small
 C_i = 15 nF

Version 3738...110.4... internal solenoid valve in type of protection Ex ia IIC (terminals 81/82 external operating voltage)
 For connection to a certified intrinsically safe current circuit only

Max. values:
 U_i = 28 V
 I_i = 115 mA
 or
 U_i = 32 V
 I_i = 87.6 mA
 L_i negligibly small
 C_i = 5 nF

Version 3738...110.0... External solenoid valve in type of protection Ex ia IIC (terminals 81/82 external operating voltage)
 For connection to a certified intrinsically safe current circuit only

Max. values:
 U_i = 28 V
 I_i = 115 mA
 or
 U_i = 32 V
 I_i = 87.6 mA
 L_i negligibly small
 C_i = 5 nF
 or

EC type examination certificate without signature not valid as issued.
 This EC type examination certificate may only be reproduced without changes.
 Exempts or modifications are to be approved by Physikalisch-Technische Bundesanstalt.
 Physikalisch-Technische Bundesanstalt - Bundesallee 100 - 38116 Braunschweig, Germany
 PTB-3738.doc

[Translation of German original]
Physikalisch-Technische Bundesanstalt
Braunschweig and Berlin

Schedule to the EC Type Examination Certificate PTB 08 ATEX 2039 X

(terminals 281/282 external solenoid valve)..... in type of protection Ex ia IIC

U_0 = 28 V
 I_0 = 115 mA

or

U_0 = 32 V
 I_0 = 87,6 mA
 P_0 = 1 W

Linear characteristic

L_i negligibly small
 C_i = 5 nF

L_0 = 3 mH
 C_0 = 56 nF

Observe the rules governing the interconnection of intrinsically safe current circuits (if applicable) and ensure that the application range is observed.

..... in type of protection Ex ia IIC
For connection to a certified intrinsically safe current circuit only

Max. values:

U_i = 20 V
 I_i = 60 mA
 P_i = 200 mW
 L_i negligibly small
 C_i negligibly small

or

in type of protection Ex ia IIC

U_0 = 9,55 V
 I_0 = 32 mA
 P_0 = 147 mW

Linear characteristic

L_i negligibly small
 C_i negligibly small

L_0 = 10 mH
 C_0 = 640 nF

Observe the rules governing the interconnection of intrinsically safe current circuits (if applicable) and ensure that the application range is observed.

Page 5/6

EC type examination certificates without signature nor seal are invalid.
This document is for information only.
Exempts or modifications are to be approved by Physikalisch-Technische Bundesanstalt.
Physikalisch-Technische Bundesanstalt - Bundesallee 100 - 38116 Braunschweig - Germany
PTB54-2728.doc

[Translation of German original]
Physikalisch-Technische Bundesanstalt
Braunschweig and Berlin

Schedule to the EC Type Examination Certificate PTB 08 ATEX 2039 X

(16) **Assessment and Test Report PTB Ex 09-28163**

(17) **Special conditions for safe use**

To prevent the risk of electrostatic charging, mark the plastic part of the enclosure with appropriate warning instructions.
Observe the mounting instructions wherever it is necessary to protect the equipment against mechanical influences.

(18) **Essential health and safety requirements**

Compliance with the essential health and safety requirements has been assured by compliance with the standards mentioned above.

Certification Sector for Explosion Protection Braunschweig, 16 March 2009

O/0

(Signature Jöhansmeyer, stamp: Physikalisch-Technische Bundesanstalt 56)

Dr.-Ing. U. Jöhansmeyer
Director and Professor

Page 6/6

EC type examination certificates without signature nor seal are invalid.
This document is for information only.
Exempts or modifications are to be approved by Physikalisch-Technische Bundesanstalt.
Physikalisch-Technische Bundesanstalt - Bundesallee 100 - 38116 Braunschweig - Germany
PTB54-2728.doc

1st ADDENDUM
according to Directive 94/9/EC, Annex III, Clause 6
to EC Type Examination Certificate PTB 08 ATEX 2039 X

Equipment: Type 3738--310., Electronic Limit Switch

Marking: II 2G Ex e [ia] IIC T4 or II 2D Ex tD A21 IP 65 T80 °C

Manufacturer: SAMSON AG Mess- und Regeltechnik

Address: Weismüllerstr. 3, D-60314 Frankfurt, Germany

Description of additions and modifications

The Type 3738--110, Electronic Limit Switch is expanded by the Type 3738--310.
The Type 3738--310. is used for electrically safe and intrinsically safe NAMUR contacts and to non-intrinsically safe solenoid valves in types of protection Ex d e, Ex e or Ex e mb.

The limit switch is intended for use in hazardous areas.

The following table lists the relation between equipment type, type of protection, temperature class and permissible ambient temperature range:

Type	Type of protection	Temperature class	Permissible ambient temperature range
3738--110.,	Ex ia IIC	T6	-40 °C to 55 °C
		T5	-40 °C to 70 °C
3738--310.,	Ex e [ia] IIC	T4	-40 °C to 80 °C
		T4	-40 °C to 80 °C

Electric data

Voltage supply:..... Max. values:
(terminals 81/82) U = 24V DC
U_m = 60V
P = 18W

External solenoid valve Max. values:
(terminals 281/282) U = 24V DC
U_m = 60V
P = 18W

Supply current circuit
using limit switch (A) NAMUR contact
(terminals 41/42) in type of protection Ex ia IIC
For connection to a certified
intrinsically safe current circuit only

This EC Type Examination Certificate may be reproduced, but the copyright is reserved. Extracts or
translations shall require the prior approval of the Physikalisch-Technische Bundesanstalt.
Physikalisch Technische Bundesanstalt Braunschweig, 100-0-38118 Braunschweig
PTB54-Add-1.doc Page 1 of 2

2nd ADDENDUM
according to Directive 94/9/EC, Annex III, Clause 6
to EC Type Examination Certificate PTB 08 ATEX 2039 X

Equipment: Type 3738...-110..., Type 3738...-310... and Type 3738...-810...
Electronic Limit Switch

Marking: II 2 G Ex ia IIC T6 and II 2 D Ex ia IIC T80 °C IP 66 or
II 2 G Ex eb [Ia] IIC T4 and II 2 D Ex Ib IIC T80 °C IP 66 or
II 3 G Ex ic IIC T4 and II 3 G Ex nA II T4 Gc and
II 3 D Ex tc IIC T80 °C IP 66

Manufacturer: SAMSON AG, Mess- und Regeltechnik
Address: Weismüllerstraße 3, 60314 Frankfurt, Germany

Description of additions and modifications

The Type 3738...-110... and Type 3738...-310... Electronic Limit Switches are expanded by the Type 3738...-810...
The Type 3738...-810... in type of protection Ex ic or Ex nA is used to energize external solenoid valves. The limit switch is intended for use in hazardous areas of zone 2 or 22.

The following table lists the relation between equipment type, type of protection, temperature class and permissible ambient temperature range:

Type	Types of protection	Temperature class	Permissible ambient temperature range
3738...-110...	Ex ia IIC	T6	-40 °C to 55 °C
		T5	-40 °C to 70 °C
		T4	-40 °C to 80 °C
3738...-310...	Ex eb [Ia] IIC	T4	-40 °C to 80 °C
3738...-810...	Ex ic IIC or Ex nA II	T4	-40 °C to 80 °C

EC type examination certificates without signature are invalid.
This EC type examination certificates may only be reproduced without changes.
Excepts or modifications are to be approved by Physikalisch-Technische Bundesanstalt.
Physikalisch-Technische Bundesanstalt · Bundesallee 100 · 38116 Braunschweig · Germany
PTB54-Ad5-2.doc

2nd Addendum to EC Type Examination Certificate PTB 08 ATEX 2039 X

Electric data

Voltage supply..... in type of protection Ex ic IIC (terminals 8/162)

Max. values:

- U_i = 32 V DC
- I_i = 100 mA
- C_i = 5 nF
- L_i negligibly small

or
in type of protection Ex nA II

- Operating values:
- U₀ = 24 V
- U_n = 60 V

Supply current circuit..... in type of protection Ex ic IIC using limit switch (A) NAMUFR contact (terminals 4/142)

Max. values:

- U_i = 32 V DC
- I_i = 100 mA
- C_i = 5 nF
- L_i negligibly small

or

in type of protection Ex nA II

- Operating values:
- U₀ = 8 V
- R_i = 1 kΩ (EN 60947-5-6)

Limit switches (B/C) NAMUFR contacts..... in type of protection Ex ic IIC (terminals 5/162 or 6/162)

Max. values per limit switch:

- U_i = 20 V DC
- I_i = 60 mA
- C_i = 15 nF
- L_i negligibly small

or

in type of protection Ex nA II

- Operating values:
- U₀ = 8 V
- R_i = 1 kΩ (EN 60947-5-6)

EC type examination certificates without signature are invalid.
This EC type examination certificates may only be reproduced without changes.
Excepts or modifications are to be approved by Physikalisch-Technische Bundesanstalt.
Physikalisch-Technische Bundesanstalt · Bundesallee 100 · 38116 Braunschweig · Germany
PTB54-Ad5-2.doc

[Translation of German original]
 Physikalisch-Technische Bundesanstalt
 Braunschweig und Berlin

2nd Addendum to EC Type Examination Certificate PTB 08 ATEX 2039 X

Limit switches (status)..... in type of protection Ex ic IIC
 (terminals 83/84)

Max. values:

- U₀ = 20 V DC
- I₀ = 40 mA
- C₀ = 56 nF
- L₀ = negligibly small

or

in type of protection Ex nA II

Operating values:

- U₀ = 8 V
- I₀ = 1 kA (EN 60947-5-6)

External solenoid valve..... in type of protection Ex ic IIC
 (terminals 281/282)

Max. values:

- U₀ = 32 V DC
 - I₀ = 100 mA
- Linear characteristic
- C₀ = 56 nF
 - L₀ = 3 mH
 - C₁ = 5 nF
 - L₁ = negligibly small

or

in type of protection Ex nA II

Operating values:

- U₀ = 24 V
- U_m = 60 V

Observe the rules governing the interconnection of intrinsically safe current circuits (if applicable) and ensure that the application range is observed.

SSP interface..... in type of protection Ex ic IIC
 (connector)

Max. values:

- U₀ = 20 V DC
- I₀ = 60 mA
- C₀ = negligibly small
- L₀ = negligibly small

EC type examination certificates without signature nor seal are invalid.
 The EC type examination certificates may only be reproduced without changes.
 Exempts or modifications are to be approved by Physikalisch-Technische Bundesanstalt.
 Physikalisch-Technische Bundesanstalt - Bundesallee 100 - 38116 Braunschweig - Germany
 PB54_Ad4-2.doc



[Translation of German original]
 Physikalisch-Technische Bundesanstalt
 Braunschweig und Berlin

2nd Addendum to EC Type Examination Certificate PTB 08 ATEX 2039 X

or

- U₀ = 9.55 V DC
 - I₀ = 32 mA
 - P₀ = 147 mW
- Linear characteristic

- C₀ = 640 nF
- L₀ = 10 mH
- C₁ = 5 nF
- L₁ = negligibly small

or

in type of protection Ex nA II

Operating values:

- U₀ = 8 V
- I₀ = 20 mA

Observe the rules governing the interconnection of intrinsically safe current circuits (if applicable) and ensure that the application range is observed.

The special conditions and all specifications of the EC type examination certificate remain valid without changes.

Applied standards

EN 60079-0:2009 EN 60079-7:2007 EN 60079-11:2007 EN 60079-31:2009

Assessment and Test Report PTB Ex 12-21067

Certification Sector for Explosion Protection

Oto Braunschweig, 2 February 2012

(Signature: Johannsmeyer, stamp: Physikalisch-Technische Bundesanstalt 24)

Dr.-Ing. U. Johannsmeyer

Director and Professor

EC type examination certificates without signature nor seal are invalid.
 The EC type examination certificates may only be reproduced without changes.
 Exempts or modifications are to be approved by Physikalisch-Technische Bundesanstalt.
 Physikalisch-Technische Bundesanstalt - Bundesallee 100 - 38116 Braunschweig - Germany
 PB54_Ad4-2.doc

3. SUPPLEMENT

according to Directive 94/9/EC Annex III.6

to EC-TYPE-EXAMINATION CERTIFICATE PTB 08 ATEX 2039 X

(Translation)

Equipment: Electronic limit signal transducer, types 3738-40;-10 and 3738-50;-10

Marking:  I 2 G Ex ia IIC T6 and II 2 D Ex ia IIC T60 °C IP66 or II 2 G Ex eb IIC T4 and II 2 D Ex to IIC T60 °C IP66 or III 3 G Ex ic IIC T4 and III 3 G Ex nA II T4 and III 3 D Ex tc IIC T60 °C IP66

Manufacturer: SAMSON AG Mess- und Regeltechnik

Address: Weimüllerstr. 3, 60314 Frankfurt, Germany

Description of supplements and modifications

The electronic limit signal transducers of type series 3738-...-10 are supplemented by types 3738-40;-10 and 3738-50;-10. Construction is carried out alternatively according to PROFIBUS PA (Type 3738-40) or FOUNDATION Fieldbus specification (Type 3738-50).

Types 3738-40-810, and type 3738-50-810, which are designed to Ex ic or Ex nA type of protection are intended for the application in hazardous areas of zones 2 or 22 respectively.

For relationship between types of protection, temperature class and the permissible ambient temperature ranges, reference is made to the table:

Type	Type of protection	Temperature class	Permissible range of the ambient temperature
3738-40-110.. 3738-50-110..	Ex ia IIC	T8	-40 °C ... 55 °C
		T5	-40 °C ... 70 °C
		T4	-40 °C ... 80 °C
3738-40-310.. 3738-40-310..	Ex eb IIC	T8	-40 °C ... 80 °C
		T4	-40 °C ... 80 °C
3738-40-810.. 3738-50-810..	Ex ic IIC b2w. Ex nA II	T8	-40 °C ... 55 °C
		T5	-40 °C ... 70 °C
		T4	-40 °C ... 80 °C

Normal dotm

Sheet 1/7

EC-type-examination Certificates without signature and official stamp shall not be valid. The certificates may be cancelled in case of original loss. Extracts or alterations are subject to approval by the Physikalisch-Technische Bundesanstalt, only without alteration. Extracts or alterations are subject to approval by the Physikalisch-Technische Bundesanstalt.

Physikalisch-Technische Bundesanstalt • Bundesallee 100 • 38116 Braunschweig • GERMANY

3. SUPPLEMENT TO EC-TYPE-EXAMINATION CERTIFICATE PTB 08 ATEX 2039 X

Electrical data

The electrical data for the types of protection Ex ia, Ex ic and Ex nA are represented below. The special conditions, the electrical data for type 3738-20;-10 and all other specifications of the EC-type examination certificate and its supplements apply without changes.

BUS-terminal, signal circuit.....type of protection Ex ia IIC/IB
For relationship between type of protection and permissible electrical data, reference is made to the following tables:

Type 3738-40

PROFIBUS PA	
Ex ia IIC	Ex ia IIB
U _i = 17,5 V DC	
I _i = 380 mA	
P _i = 5,32 W	

or

Type 3738-50

FOUNDATION™ Fieldbus	
Ex ia IIC	Ex ia IIB
U _i = 24 V DC	U _i = 24 V DC
I _i = 380 mA	I _i = 390 mA
P _i = 1,04 W	P _i = 2,58 W

C_i = 5 nFL_i = 10 µH

or

BUS-terminal, signal circuit.....type of protection Ex ic IIC/IB

Type of protection	U _i [VDC]	I _i [mA]	P _i [W]
Ex ic IIC	20	484	2,32
	24	281	1,56
	32	132	1,04
Ex ic IIB	20	1170	5,88
	24	650	3,89
	32	324	2,77

Sheet 2/7

EC-type-examination Certificates without signature and official stamp shall not be valid. The certificates may be cancelled in case of original loss. Extracts or alterations are subject to approval by the Physikalisch-Technische Bundesanstalt, only without alteration. Extracts or alterations are subject to approval by the Physikalisch-Technische Bundesanstalt.

Physikalisch-Technische Bundesanstalt • Bundesallee 100 • 38116 Braunschweig • GERMANY



Physikalisch-Technische Bundesanstalt

Braunschweig und Berlin

3. SUPPLEMENT TO EC-TYPE EXAMINATION CERTIFICATE PTB 08 ATEX 2039 X

$C_i = 5 \text{ nF}$
 $L_i = 10 \text{ }\mu\text{H}$

or

type of protection: Ex (nA II)
 $U_b = 9 \dots 24 \text{ VDC}$
 $I_b = 15 \text{ mA}$

Solenoid, internal internal circuit without external connection facilities (plug connector ASRX2)

type of protection: Ex ia IIC/IB
 Maximum values: Bus-interfacing

Note: Only one of the following options will be applied in each case.

Option External Solenoid $U_b = 6 \text{ VDC}$ type of protection: Ex ia IIC/IB
 Maximum values: Bus-interfacing
 $L_i = \text{negligibly low}$
 $C_i = 5 \text{ nF}$

Voltage supply BUS-connection type of protection: Ex ic IIC/IB
 (terminal V_{ext})
 Maximum values: Bus-interfacing
 $L_i = \text{negligibly low}$
 $C_i = 5 \text{ nF}$

or
 type of protection: Ex nA II
 Maximum values: Bus-interfacing

Option External Solenoid $U_b = 24 \text{ VDC}$
 Signal input/output type of protection: Ex eb II
 (terminals 61+V62-, 281+V282-)

Operating values:
 $U_b = 24 \text{ VDC}$
 $U_m = 60 \text{ VDC}$
 $P_i = 18 \text{ W}$

Sheet 3/7

EC-type examination Certificates without signature and official stamp shall not be valid. The certificates may be circulated only without alteration. Extracts or alterations are possible only with the approval of the Physikalisch-Technische Bundesanstalt.

Physikalisch-Technische Bundesanstalt • Bundesallee 100 • 38116 Braunschweig • GERMANY



Physikalisch-Technische Bundesanstalt

Braunschweig und Berlin

3. SUPPLEMENT TO EC-TYPE EXAMINATION CERTIFICATE PTB 08 ATEX 2039 X

Option External Solenoid $U_b = 24 \text{ VDC}$

Signal input type of protection: Ex ia IIC/IB
 (terminals 81+V82-)

Maximum values:
 $U_b = 28 \text{ VDC}$
 $I_b = 115 \text{ mA}$
 $P_i = 1 \text{ W}$

or
 $U_b = 32 \text{ VDC}$
 $I_b = 87.8 \text{ mA}$
 $P_i = 1 \text{ W}$
 $L_i = \text{negligibly low}$
 $C_i = 5 \text{ nF}$

Signal output type of protection: Ex ia IIC/IB
 (terminals 281+V281-)

Maximum values:
 $U_b = 28 \text{ VDC}$
 $I_b = 115 \text{ mA}$
 $P_i = 1 \text{ W}$

or
 $U_b = 32 \text{ VDC}$
 $I_b = 87.8 \text{ mA}$
 $P_i = 1 \text{ W}$
 linear characteristic
 $L_i = 10 \text{ mH}$
 $C_i = 150 \text{ nF}$
 $L_i = \text{negligibly low}$
 $C_i = 5 \text{ nF}$

Signal interface SSP type of protection: Ex ia IIC/IB
 (plug connector)

Maximum values (passive):
 $U_b = 20 \text{ VDC}$
 $I_b = 60 \text{ mA}$
 $P_i = 200 \text{ mW}$
 $L_i = \text{negligibly low}$
 $C_i = \text{negligibly low}$

Sheet 4/7

EC-type examination Certificates without signature and official stamp shall not be valid. The certificates may be circulated only without alteration. Extracts or alterations are possible only with the approval of the Physikalisch-Technische Bundesanstalt.

Physikalisch-Technische Bundesanstalt • Bundesallee 100 • 38116 Braunschweig • GERMANY

or

Maximum values (active):

 $U_0 = 5,35 \text{ V DC}$
 $I_0 = 35 \text{ mA}$
 $P_0 = 50 \text{ mW}$
 linear characteristic.

For relationship between type of protection, explosion group and permissible external reactances, reference is made to the table:

Ex Ia	L ₀	C ₀
IC	10 mH	1,7 µF
IB	10 mH	12 µF

or

type of protection Ex Ia IIC/IB

Maximum values (passive):

 $U_0 = 20 \text{ V DC}$
 $I_0 = 60 \text{ mA}$
 $P_0 = 200 \text{ mW}$
 L_0 negligibly low
 C_0 negligibly low

or

Maximum values (active):

 $U_0 = 5,35 \text{ V DC}$
 $I_0 = 35 \text{ mA}$
 $P_0 = 50 \text{ mW}$
 linear characteristic

For relationship between type of protection, explosion group and permissible external reactances, reference is made to the table:

Ex Ia	L ₀	C ₀
IC	10 mH	3,1 µF
IB	10 mH	19 µF

Sheet 5/7

EC-Type-examination Certificates without signature and official stamp shall not be valid. The certificates may be cancelled only without alteration. Extracts or alterations are subject to approval by the Physikalisch-Technische Bundesanstalt.

Physikalisch-Technische Bundesanstalt • Bundesallee 110 • 38116 Braunschweig • GERMANY

 L_0 negligibly low
 $C_0 = 5 \text{ nF}$
 or

type of protection Ex Ia II

Operating values:

 $U_0 = 8 \text{ V}$
 $I_0 = 20 \text{ mA}$

The rules for the interconnection of intrinsically safe circuits shall be observed where applicable and the adherence to the field of application shall be safeguarded.

 Binary input, activetype of protection Ex Ia IIC/IB
 (terminals 85+/86-)

Maximum values:

 $U_0 = 20 \text{ V}$
 $I_0 = 60 \text{ mA}$
 $P_0 = 200 \text{ mW}$
 L_0 negligibly low
 C_0 negligibly low

or

type of protection Ex Ia II

Operating values:

 $U_0 = 30 \text{ V}$

 Binary input, passivetype of protection Ex Ia IIC/IB
 (terminals 67+/68-)

Maximum values:

 $U_0 = 30 \text{ V}$
 $I_0 = 100 \text{ mA}$
 L_0 negligibly low
 $C_0 = 110 \text{ nF}$

or

 Binary input, activetype of protection Ex Ia IIC/IB
 (terminals 85+/86-)

Maximum values:

 $U_0 = 30 \text{ V}$
 $I_0 = 152 \text{ mA}$

Sheet 6/7

EC-Type-examination Certificates without signature and official stamp shall not be valid. The certificates may be cancelled only without alteration. Extracts or alterations are subject to approval by the Physikalisch-Technische Bundesanstalt.

Physikalisch-Technische Bundesanstalt • Bundesallee 110 • 38116 Braunschweig • GERMANY



Physikalisch-Technische Bundesanstalt

Braunschweig und Berlin

3. SUPPLEMENT TO EC-TYPE-EXAMINATION CERTIFICATE PTB 08 ATEX 2039 X

L_i negligibly low
C_i negligibly low
or

type of protection Ex:nA II

Operating value:

U₀ = 30 V

Binary input, passivetype of protection Ex:ic IIC/IIIB
(terminals 87+985-)

Maximum values:

U_i = 32 V

I_i = 132 mA

L_i negligibly low

C_i = 110 nF

or

type of protection Ex:nA II

Operating value:

U₀ = 32 V

Applied standards

EN 60079-0:2009

EN 60079-7:2007

EN 60079-11:2012

EN 60079-27:2008

EN 60079-31:2009

Test report: PTB Ex 12-21143

Braunschweig, July 19, 2012

Zertifizierungs-Aktor Explosiveschutz
 On behalf of PTB:

 Dr.-Ing. U. Johannes
 Direktor und Professor



Sheet 7/7

EC-Type-examination Certificates without signature and official stamp shall not be valid. The certificate may be circulated only without alteration. Extracts or alterations are not approved. Physikalisch-Technische Bundesanstalt, Braunschweig und Berlin.

Physikalisch-Technische Bundesanstalt • Bundesallee 100 • 38116 Braunschweig • GERMANY



EU Konformitätserklärung / EU Declaration of Conformity / Déclaration UE de conformité

Die alleinige Verantwortung für die Ausstellung dieser Konformitätserklärung trägt der Hersteller/
This declaration of conformity is issued under the sole responsibility of the manufacturer/
La présente déclaration de conformité est établie sous la seule responsabilité du fabricant.

Für das folgende Produkt / For the following product / Nous certifions que le produit

Grenzsinalgeber / Limit Switch / Contacts de position Typ/Type/Type 3738--..000

wird die Konformität mit den einschlägigen Harmonisierungsrechtsvorschriften der Union bestätigt /
the conformity with the relevant Union harmonisation legislation is declared with /
est conforme à la législation d'harmonisation de l'Union applicable selon les normes:

EMC 2014/30/EU

EN 61000-6-2:2005, EN 61000-6-3:2007
+A1:2011, EN 61326-1:2013

RoHS 2011/65/EU

EN 50581:2012

Hersteller / Manufacturer / Fabricant:

SAMSON AKTIENGESELLSCHAFT
Weismüllerstraße 3
D-60314 Frankfurt am Main
Deutschland/Germany/Allemagne

Frankfurt / Francfort, 2017-07-29

Im Namen des Herstellers/ On behalf of the Manufacturer/ Au nom du fabricant.

Hanno Zager
Leiter Qualitätssicherung/Head of Quality Management/
Responsable de l'assurance de la qualité

Dirk Hoffmann
Zentralabteilungsleiter/Head of Department/Chef du département
Entwicklungsorganisation/Development Organization

cs_3738_000_de_en_fr_rev07.pdf



EU Konformitätserklärung / EU Declaration of Conformity / Déclaration UE de conformité

Die alleinige Verantwortung für die Ausstellung dieser Konformitätserklärung trägt der Hersteller/
This declaration of conformity is issued under the sole responsibility of the manufacturer/
La présente déclaration de conformité est établie sous la seule responsabilité du fabricant.
Für das folgende Produkt / For the following product / Nous certifions que le produit

Grenzsignalgeber / Limit Switch / Contacts de position Typ/Type/Type 3738-20-110, -20-310, -20-810

entsprechend der EU-Baumusterprüfbescheinigung PTB 08 ATEX 2039 X ausgestellt von der/
according to the EU Type Examination PTB 08 ATEX 2039 X issued by/
établi selon le certificat CE d'essais sur échantillons PTB 08 ATEX 2039 X émis par:

Physikalisch Technische Bundesanstalt
Bundesallee 100
D-38116 Braunschweig

Benannte Stelle/Notified Body/Organisme notifié 0102

wird die Konformität mit den einschlägigen Harmonisierungsrechtsvorschriften der Union bestätigt/
the conformity with the relevant Union harmonisation legislation is declared with/
est conforme à la législation d'harmonisation de l'Union applicable selon les normes:

EMC 2014/30/EU

EN 61000-6-2:2005, EN 61000-6-3:2007
+A1:2011, EN 61326-1:2013

Explosion Protection 2014/34/EU

EN 60079-0:2012/A11:2013, EN 60079-7:2015,
EN 60079-11:2012, EN 60079-15:2010,
EN 60079-31:2014

RoHS 2011/65/EU

EN 50581:2012

Hersteller / Manufacturer / Fabricant:

SAMSON AKTIENGESELLSCHAFT
Weismüllerstraße 3
D-60314 Frankfurt am Main
Deutschland/Germany/Allemagne

Frankfurt / Francfort, 2018-12-17

Im Namen des Herstellers/ On behalf of the Manufacturer/ Au nom du fabricant.

Dr. Julian Fuchs
Zentralabteilungsleiter/Head of Department/Chef du département
Entwicklung Ventilanbaugeräte und Messtechnik
Development Valve Attachments and Measurement Technologies

Dipl.-Ing. Silke Bianca Schäfer
Total Quality Management/
Management par la qualité totale

ce_3738_...110_de_en_fr_en08.pdf

Parameter list

P0	Info: actual value
P1	Reading direction
P2	Configuration: RUN/SET
P3	Verify LCD segments (TSTD)
P4*	Actuator type
P5*	Actuator's direction of action
P6*	Switching function of contacts A, B, C
P7*	Switching contact, lower end position
P8*	Switching contact, upper end position
P9*	Automatic initialization (INIA)
P10*	Manual initialization (INIM)
P11*	End position calibration (REF)
P12*	Issue status PST target range
P13*	Status indication actuator transit time
P14*	PST step end
P15*	PST tolerance band
P16*	Start automatic PST
P17*	Start manual PST (PST)
P18*	Lock operation
P19*	Testing contacts A, B, B_LB, C, St (TSTC)
P20*	Testing solenoid valve (TSTS)
P21*	Reset (RST)
P22	Info: actuator transit time when solenoid valve is de-energized
P23	Info: actuator transit time when solenoid valve is energized
P24	Info: temperature
P25	Info: operating hours
P26*	Max. rotary motions
P27*	Reset rotary motion counter
P28	Info: firmware version

Status messages

F0	Stationary outside required/desired end positions
F1	Left end position without being required to move
F2	Limit of P26 exceeded
F3	Temperature limits exceeded
F4	Actuator transit time exceeded
F5	Actuator stationary when required to move
F6	Min. value for PST not reached
F7	Max. value for PST exceeded
F8	No switching voltage during PST
F9	Time-out during PST
F10	Error E0 to E10 exists
F15	Configuration mode SET activated

Error messages

E0	No initialization
E1	INIT: actuator does not move
E2	INIT: min. travel not reached
E3	INIT: max. travel exceeded
E4	INIT: actuator travels too fast
E5	INIT: no switching voltage applied
E6	INIT: time-out
E7	Function canceled
E8	Unable to calibrate end positions
E9	Device error 1
E10	Device error 2

The parameters/errors marked with an asterisk (*) can only be changed/confirmed in the SET configuration mode.

Assignment based on the direction of action

PTO (power to open)

	+	-	Position	Switching contact for end position
Contact A	41	42	Fail-safe position (0 %) · Valve CLOSED	P7 (0.5 to 96.0 %, [2.0 %])
Contact B	51	52	Operating position (100 %) · Valve OPEN	P8 (4.0 to 99.5 %, [98.0 %])

PTC (power to close)

	+	-	Position	Switching contact for end position
Contact A	41	42	Fail-safe position (100 %) · Valve OPEN	P8 (4.0 to 99.5 %, [98.0 %])
Contact B	51	52	Operating position (0 %) · Valve CLOSED	P7 (0.5 to 96.0 %, [2.0 %])

Key number

42

EB 8390 EN



SAMSON AKTIENGESELLSCHAFT
Weismüllerstraße 3 · 60314 Frankfurt am Main, Germany
Phone: +49 69 4009-0 · Fax: +49 69 4009-1507
samson@samsongroup.com · www.samsongroup.com