

Position Transmitter Type 4748



Fig. 1 · Type 4748 Position Transmitter

Mounting and Operating Instructions

EB 8363 EN

Edition December 2007



General safety instructions



- ▶ *The position transmitter may only be assembled, started up or operated by trained and experienced personnel familiar with the product. According to these mounting and operating instructions, trained personnel is referred to as individuals who are able to judge the work they are assigned to and recognize possible dangers due to their specialized training, their knowledge and experience as well as their knowledge of the relevant standards.*
 - ▶ *Explosion-protected versions of this device may only be operated by personnel who have undergone special training or instructions or who are authorized to work on explosion-protected devices in hazardous areas.*
 - ▶ *Any hazards that could be caused by the process medium, the operating pressure, the signal pressure or by moving parts of the control valve are to be prevented by means of the appropriate measures. If inadmissible motions or forces are produced in the actuator as a result of the supply pressure level, it must be restricted by means of a suitable supply pressure reducing station.*
 - ▶ *Proper shipping and appropriate storage are assumed.*
 - ▶ **Note!**
The device with a CE marking fulfils the requirements of the Directives 94/9/EC (ATEX) and 89/336/EEC (EMC).
-

Contents	Page
1	Design and principle of operation 4
	Technical data 5
2	Attachment 6
2.1	Attachment to control valve 6
2.1.1	Attachment to valve with cast yoke 6
2.1.2	Attachment to valve with rod-type yoke 6
2.2	Attachment to positioner 9
2.3	Housing cover 9
3	Electrical connection 10
4	Operation 10
4.1	Adjusting the position transmitter. 10
4.1.1	Direction of action. 10
4.2	Adjusting zero and span 10
4.2.1	Zero adjustment. 11
4.2.2	Span adjustment 11
	Test certificates 13

1 Design and principle of operation

The Type 4748 Position Transmitter is used to assign a certain relationship between the valve position (travel) and the analog output signal of 4 to 20 mA. If the output signal is transmitted to an indicating instrument, the

present travel position can be monitored. The position transmitter is attached to the control valve either directly or in combination with the Type 4763 and Type 4765 Positioner.

The pin (1.1) and the lever (1) convert the travel of the control valve into a rotary motion which is transmitted to the solenoid sys-

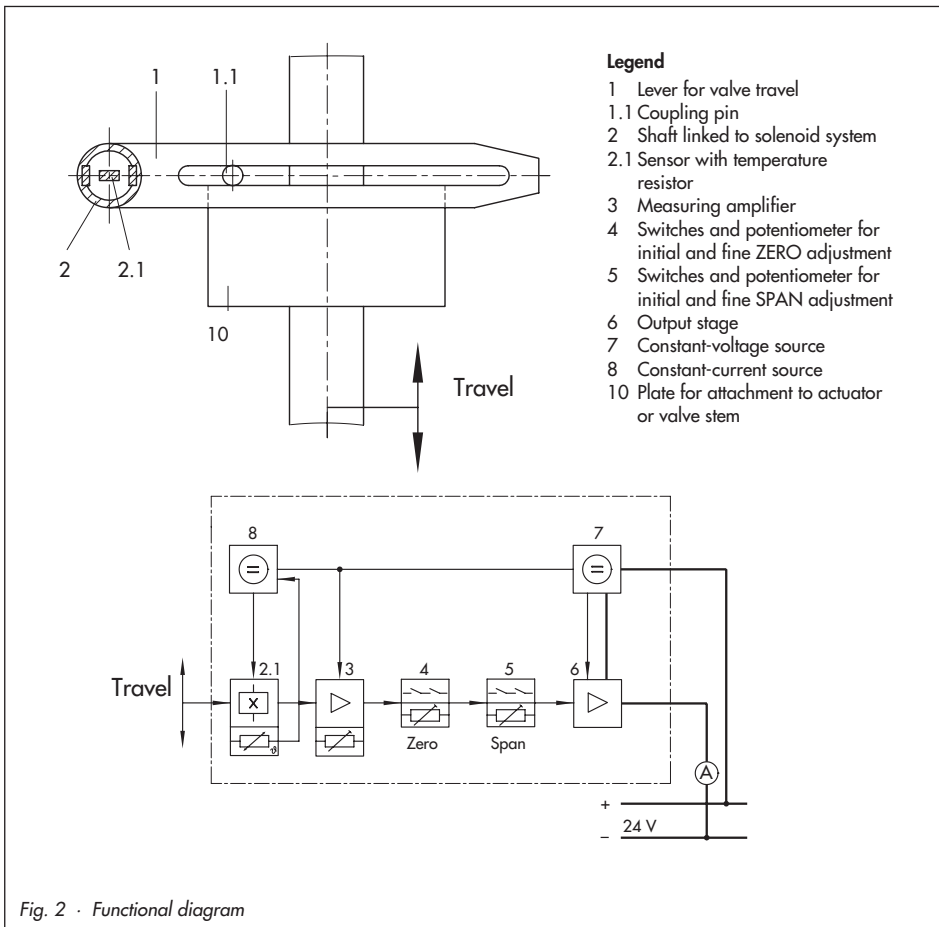

1.1 Technical data

Type	4748-0	4748-1
Output signal	Two-wire circuit 4 to 20 mA	
Permissible load	$R_b = \frac{U_s - 12 V}{20 \text{ mA}}$	
Output circuit	–	Intrinsically safe
Auxiliary power	Two-wire network 24 V Voltage range 12 to 45 V For connection to intrinsically safe circuits with maximum values $U_O = 25 \text{ V}$, $I_K = 100 \text{ mA}$, $P = 0.8 \text{ W}$ (effective internal inductance and capacitance are negligibly small) ¹⁾	
Performance	Characteristic: Output linear to input Deviation from terminal-based conformity: $\leq 1 \%$ ²⁾	
Hysteresis	$\leq 0.6 \%$ ³⁾	
Response	$\leq 0.1 \%$	
Influence on auxiliary power	$\leq 0.1 \%$ on span changes within the specified limits	
HF effect	$\leq 1 \%$, $f = 150 \text{ MHz}$, 1 Watt transmission power, 0.5 m distance	
Load influence	$\leq 0.1 \%$	
Permissible ambient temperature	–20 to +70 °C	Max. 60 °C, temperature class T6 The limits specified in the EC Type Examination Certificate additionally apply for explosion-protected devices
Effect of ambient temperature	$\leq 0.3 \%$ /10 K on lower measuring range and measuring span ²⁾	
Ripple of output signal	$\leq 0.3 \%$	
Min./max. travel ranges	1 Attachment to Type 4763/4765 Positioner: 7 to 60 mm 2 Lever I: 7 to 60 mm Lever II: > 60 to 103 mm (up to 120 mm on request)	
Materials	Housing: Die-cast aluminum, plastic coated External parts: 1.4571, black anodized aluminum	
Weight	Approx. 0.7 kg	
Degree of protection	With direct attachment: IP 65 When attached to a positioner: IP 54 (IP 65 on request)	

¹⁾ e.g. SAMSOMATIC Type 994-0103-cs-412 Loop Isolator or Type 994-0103-cmc-0305-5 DC Isolator

²⁾ At max. travel 100 % = 32° lever angle

³⁾ At max. travel 100 % = 8° lever angle

tem (2) of the position transmitter. This causes a change in the magnetic field as well as in the voltage in the sensor (2.1) that operates according to the Hall effect. The connected electronics unit converts the resulting voltage into a load-independent current signal of 4 to 20 mA.

To adjust zero and span, the position transmitter has 4 microswitches for initial adjustment and 2 potentiometers for fine adjustment. The output characteristic of the position indication may be reversed by a connector that can be turned by 180°. By doing this, the closed position of the valve may optionally be represented by a current signal of either 4 mA or 20 mA.

2 Attachment

The accessories listed in the table below are required for attachment.

2.1 Attachment to control valve

The required lever (I or II) must be mounted to the control valve prior to attaching the position transmitter (refer to Fig. 3). To do this, push the clamping plate (1.1) over the lever (1) and place them together on the shaft. Tighten the fastening screw.

2.1.1 Attachment to valve with cast yoke

1. Fasten the plate (10) to the stem connector clamp of the valve using the screws (10.1).
2. Fasten the pin (11) to the plate (10) using the two nuts (11.1).
3. Unscrew the cover of the position transmitter. Fasten it to the valve yoke using the screw (12), washer (13) and O-ring (14). Make sure that the pin (11) is located inside the wire bracket (1.3) of the lever (1).

2.1.2 Attachment to valve with rod-type yoke

1. Fasten plate (10) to the stem connector clamp of the valve using screws (10.1) (refer to Fig. 3).
2. Fasten the pin (11) to the plate (10) using the two nuts (11.1).
3. Place the support (15) and fixing plate (16) on the valve stem and fasten lightly. Move the support until the middle of the plate (10) and the support (15) are aligned when the valve is at mid-travel.

Accessories for attachment according to IEC 60534-6

Valve	Valve with cast yoke (NAMUR rib)		Valve with rod-type yoke (∅ 18 to 32 mm)	
Travel	Up to 60 mm	Up to 103 mm	Up to 60 mm	Up to 103 mm
Attachment unit order no.	1400-6713 (Lever I)	1400-6714 (Lever II)	1400-6713 (Lever I) plus 1400-5342	1400-6714 (Lever II) plus 1400-5342
Accessories for attachment to Type 4763 and Type 4765 Positioner				
Attachment unit	Order no. 1400-6710			

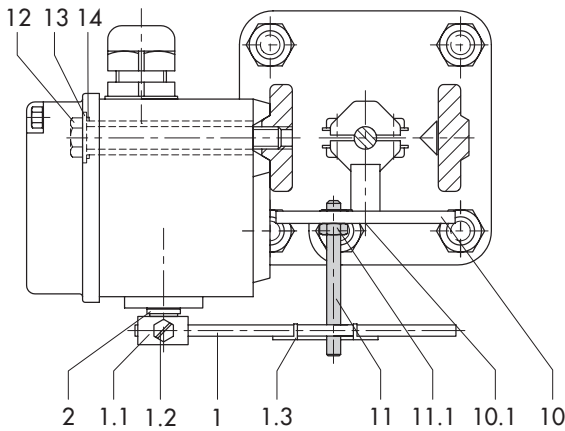

Attachment to valve with cast yoke (NAMUR rib)

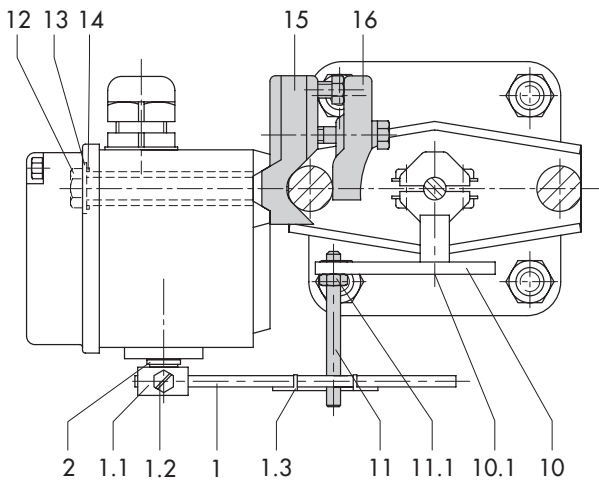

Attachment to valve with rod-type yoke

Legend



- 1 Lever
- 1.1 Clamping plate
- 1.2 Screw
- 1.3 Wire bracket
- 2 Shaft
- 10 Plate
- 10.1 Screws
- 11 Pin
- 11.1 Nuts
- 12 Screw
- 13 Washer
- 14 O-ring
- 15 Support
- 16 Fixing plate

Fig. 3 · Attachment to control valves

4. Screw support (15) and fixing plate (16) tight.
5. Mount the position transmitter to the support using the screw (12), washer (13) and O-ring (14).
Make sure that the pin (11) is located inside the wire bracket (1.3) of the lever (1).

Note!

After attaching the position transmitter, make sure that the venting plug on the housing cover faces downwards when the valve is installed in the pipeline.

Mounting position at the valve: Viewed from the top of the plate (10) with the actuator facing upward							
Direct attachment (left) and attachment on positioner (right)				Direct attachment (right) and attachment on positioner (left)			
Lever position	Valve	Direction of action (symbol on connector)		Direction of action (symbol on connector)		Valve	Lever position
		<>	>>	<>	>>		
	OPEN	20 mA	4 mA	4 mA	20 mA	OPEN	
	CLOSED	4 mA	20 mA	20 mA	4 mA	CLOSED	

2.2 Attachment to positioner

For attachment to the Type 4765 and Type 4763 Positioner with a short lever, proceed as follows:

Place O-rings (30) on the left and the right side of the intermediate piece (31). Insert the two fillister head screws (33) in the position transmitter and the intermediate piece, and put them to the positioner. Slip the nuts (32) on the fillister head screws in the positioner housing and tighten the screws (33). Fasten the pin (1.3) to the lever (1) of the positioner using the nuts (22), linking the short lever of the position transmitter with it.

Both devices have the degree of protection IP 54. For this purpose, exchange the stoppers from the positioner cover and the position transmitter cover.

To achieve IP 65: Replace venting of the position transmitter with a filter (order no. 1790-7408).

2.3 Housing cover

After mounting the position transmitter on the control valve, ensure that the vent plug in the housing cover points downwards.

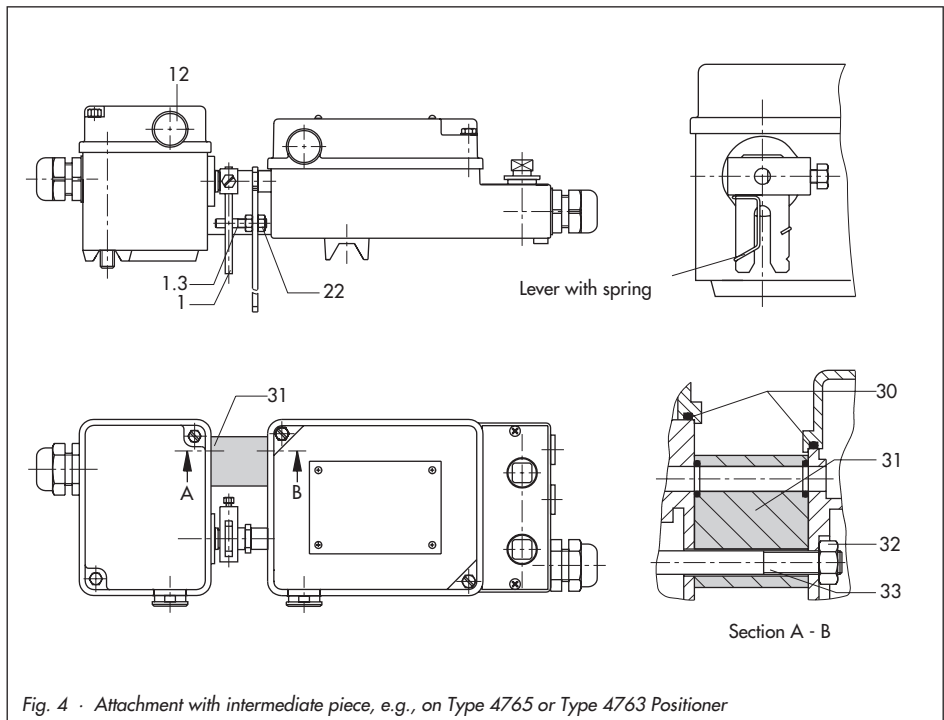

Fig. 4 · Attachment with intermediate piece, e.g., on Type 4765 or Type 4763 Positioner

3 Electrical connection

The terminal assignment can be found in Fig. 5 or on the printed circuit board.

To check the output signal during adjustment, connect an ammeter (mA scale) to the terminals 81 and 82 after temporarily removing the jumper.

A two-wire system is used to operate the position transmitter. The supply voltage usually is 24 V DC. Considering the wire resistance, the voltage directly applied to the terminals of the position transmitter must be between min. 12 to max. 45 V DC.

When used in hazardous areas, observe the installation regulations according to VDE 0165.

4 Operation

4.1 Adjusting the position transmitter

4.1.1 Direction of action

A travel of 0 to 100 % can be assigned to a feedback signal (direction of action either >> or <>) range of 4 to 20 mA or 20 to 4 mA.

The feedback signal range depends upon the mounting position (direct attachment on the left or the right side of the control valve or attachment to the positioner) as well as upon the type of actuator ("Actuator stem retracts" or "Actuator stem extends"). The desired direction of action of the output signal is determined by the 7-pole connector on the PCB (see table on page 8) and indicated by the symbols on the connector >> or <>.

To change the direction of action, gently lever off the connector and remove it. Then, turn it by 180° and plug it in again.

4.2 Adjusting zero and span

ZERO: Use the switches 3 and 4 for initial adjustment of zero point. For fine adjustment, use the ZERO potentiometer.

Usually, the zero point is based on 4 mA.

SPAN: Use the switches 1 and 2 for initial adjustment of the span and the upper range value. For fine adjustment, use the SPAN potentiometer. The span is usually based on 20 mA.

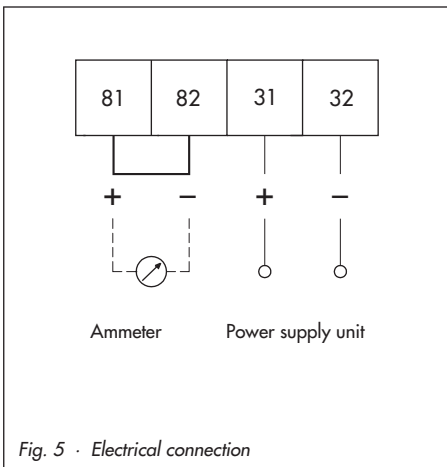

Fig. 5 · Electrical connection

Example:

With a control valve which is moved from the closed position (Valve CLOSED) to the open position (Valve OPEN), the feedback signal should pass through the signal range from 4 to 20 mA. The position transmitter is attached to the left side of the control valve. To carry out adjustments at the terminals 31 and 32, connect a suitable ammeter. To check the output signal, remove the jumper at the terminals 81 and 82 and connect a suitable ammeter (mA scale). First determine the direction of action by setting the position of the 7-pole connector. Applying the example above, the symbol on the connector must be $\langle \rangle$ according to the table (on page 8). If this is not the case, remove the connector, turn it 180° and plug it in again.

4.2.1 Zero adjustment

Move the control valve to the closed position (Valve CLOSED = travel 0 %) over the input signal of the positioner.

Take the reading from the ammeter. The reading must be approx. 4 mA. Upon slight deviation, carry out correction at the ZERO potentiometer until the reading is 4 mA. On considerable deviation, adjust the switches 3 and 4 until the issued mA value lies within the adjusting range of the ZERO potentiometer. Set the zero point exactly to 4 mA by adjusting the ZERO potentiometer.

4.2.2 Span adjustment

Move the control valve to the fully open position (Valve OPEN = travel 100 %) over the input signal of the positioner.

Take the reading from the ammeter. The reading must be approx. 20 mA. On slight deviation, carry out correction at the SPAN potentiometer until the reading is 20 mA.

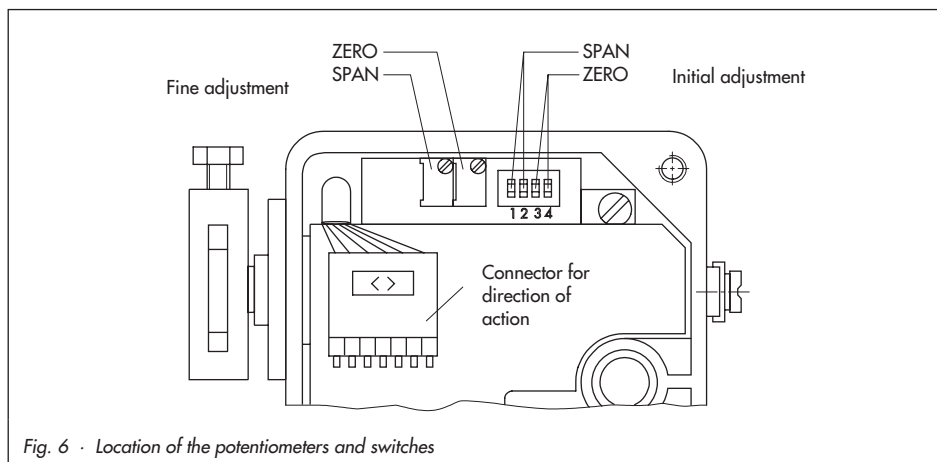

Fig. 6 · Location of the potentiometers and switches

Upon considerable deviation, adjust the switches 1 and 2 until the issued mA value lies within the adjusting range of the SPAN potentiometer. Finally, adjust the SPAN potentiometer until the ammeter exactly reads 20 mA. Since zero and span adjustment affect each other, re-adjust the potentiometers until both values are correct.

TRANSLATION

EC TYPE EXAMINATION CERTIFICATION

(1) Equipment and Protective Systems Intended for Use in Potentially Explosive Atmospheres – **Directive 94/9/EC**

(2) EC Type Examination Certificate Number

PTB 03 ATEX 2046

(3) Equipment: Model 4748-1.. Position Indicator

(4) Manufacturer: SAMSON AG, Mess- und Regeltechnik

(5) Address: Weismüllerstr. 3, D-60314 Frankfurt, Germany

(6) The equipment and any acceptable variations thereof are specified in the schedule to this certificate and the documents referred to therein..

(7) The Physikalisch-Technische Bundesanstalt, notified body number 0102, in accordance with Article 10 of the Commission Decision 94/9/EC, is responsible for this certificate and its validity. The manufacturer is responsible for this equipment and its conformity with the Essential Health and Safety Requirements relating to the design and construction of equipment and protective systems intended for use in potentially explosive atmospheres as specified in Annex II to the Directive.

The examination and test results are recorded in confidential report
PTB-Ex-03-23095.

(8) The Essential Health and Safety Requirements are satisfied by compliance with

EN 50014:1997 +A1 +A2 EN 50020:2002

(9) If the sign "X" is placed after the certificate number, it indicates that the equipment is subject to special conditions for safe use specified in the schedule to this certificate.

(10) This EC Type Examination Certificate relates only to the design and examination of the specified equipment in compliance with Directive 94/9/EC. Further requirements of this Directive apply to the manufacture and supply of this equipment. These requirements are not covered by this Certificate.

EC Type Examination Certificates without signature and seal are invalid.
This EC Type Examination Certificate may only be reproduced in its entirety and without any changes, schedule included.
Extracts or changes shall require the prior approval of the Physikalisch-Technische Bundesanstalt.

Physikalisch-Technische Bundesanstalt, Bundesallee 100, D-38116 Braunschweig

PH36-4748-16ex

(12) The marking of the equipment shall include the following:



Zertifizierungsstelle Explosionsschutz Braunschweig, 02. June 2003
By order

(Signature) (Seal)

Dr.-Ing. U. Johannsmeyer
Regierungsdirktor

EC Type Examination Certificates without signature and seal are invalid.
This EC Type Examination Certificate may only be reproduced in its entirety and without any changes, schedule included.
Extracts or changes shall require the prior approval of the Physikalisch-Technische Bundesanstalt.

Physikalisch-Technische Bundesanstalt, Bundesallee 100, D-38116 Braunschweig

PH36-4748-16ex

Physikalisch-Technische Bundesanstalt
Braunschweig und Berlin

Test Report PTB Ex 03-23095

(13) **S c h e d u l e**

(14) **EC TYPE EXAMINATION CERTIFICATE No. PTB 03 ATEX 2046**

(15) **Description of Equipment**

The Model 4748.1... Position indicator serves for monitoring the valve stem position. The valve stem is actuated by Hall sensors. The range in position of a permanent magnet dependent on the valve stem position is converted into the standard signal of 4 to 20 mA and fed to the downstream transducer electronics.

The Model 4748-1... Position indicator is a passive two-terminal network which may be connected to any intrinsically safe circuit, provided the permissible maximum values of U_i , I_i and P_i are not exceeded.

For air supply non-combustible media are used.

The device may be used inside and outside of hazardous locations.

The correlation between temperature classification and permissible ambient temperature range is shown in the table below.

Temperature class	Permissible ambient temperature range
T6	-45 °C... 60 °C
T5	-45 °C... 70 °C
T4	-45 °C... 80 °C

Electrical data

Signal circuit:
(terminal 31 / 32)

Type of protection: Intrinsic safety EX is IIC only for connection to a certified intrinsically safe circuit.

Maximum values:

U_i = 28 V

I_i = 115 mA

P_i = 1 W

C_i = 5.3 nF

L_i = negligible

EC Type Examination Certificates without signature and seal are invalid.
This EC Type Examination Certificate may only be reproduced in its entirety and without any changes, schedule included.
Extracts or changes shall require the prior approval of the Physikalisch-Technische Bundesanstalt.

Physikalisch-Technische Bundesanstalt, Bundesallee 100, D-38116 Braunschweig

PH34-4748-1de4

Physikalisch-Technische Bundesanstalt
Braunschweig und Berlin

Test Report PTB Ex 03-23095

(16) **Test Report PTB Ex 03-23095**

(17) **Special conditions for safe use**

None

(18) **Special Health and Safety Requirements**

In compliance with the standards specified above.

Braunschweig, 2. Juni 2003

Zertifizierungsstelle Explosionsschutz

By order

(Signature) (seal)

Dr.-Ing. U. Johannsmeyer
Regierungsdiraktor

EC Type Examination Certificates without signature and seal are invalid.
This EC Type Examination Certificate may only be reproduced in its entirety and without any changes, schedule included.
Extracts or changes shall require the prior approval of the Physikalisch-Technische Bundesanstalt.

Physikalisch-Technische Bundesanstalt, Bundesallee 100, D-38116 Braunschweig

PH34-4748-1de4

TRANSLATION

EC TYPE EXAMINATION CERTIFICATION

(2) Equipment and Protective Systems Intended for Use in Potentially Explosive Atmospheres – **Directive 94/9/EC**

(3) EC Type Examination Certificate Number

PTB 03 ATEX 2047 X

(4) Equipment: Model 47/48-8... Position Indicator

(5) Manufacturer: SAMSON AG, Mess- und Regeltechnik

(6) Address: Weismüllerstr. 3, D-60314 Frankfurt, Germany

(7) The equipment and any acceptable variations thereof are specified in the schedule to this certificate and the documents referred to therein...

(8) The Physikalisch-Technische Bundesanstalt, notified body number 0109, in accordance with the European Standard EN ISO 9001:2000, has issued this certificate. In this certificate, the equipment has been found to comply with the Essential Health and Safety Requirements relating to the design and construction of equipment and protective systems intended for use in potentially explosive atmospheres as specified in Annex II to the Directive.

The examination and test results are recorded in confidential report PTB-Ex-03-23095.

(9) The Essential Health and Safety Requirements are satisfied by compliance with

EN 50021:1999

(10) If the sign "X" is placed after the certificate number, it indicates that the equipment is subject to special conditions for safe use specified in the schedule to this certificate.

(11) In compliance with the Directive 94/9/EC this Statement of Conformity relates only to the design and construction of the equipment specified. Further requirements of this Directive apply to manufacture and marking of the equipment.

EC Type Examination Certificates without signature and seal are invalid.
This EC Type Examination Certificate may only be reproduced in its entirety and without any changes, schedule included.
Errors or changes still require the prior approval of the Physikalisch-Technische Bundesanstalt.

Physikalisch-Technische Bundesanstalt, Bundesallee 100, D-38116 Braunschweig

PhB36-Ex.mdx

(12) The marking of the equipment shall include the following:



Zertifizierungsstelle Explosionsschutz Braunschweig, 02. June 2003
By order

(Signature) (Seal)

Dr.-Ing. U. Jochenasmeyer
Regierungsdirktor

EC Type Examination Certificates without signature and seal are invalid.
This EC Type Examination Certificate may only be reproduced in its entirety and without any changes, schedule included.
Errors or changes still require the prior approval of the Physikalisch-Technische Bundesanstalt.

Physikalisch-Technische Bundesanstalt, Bundesallee 100, D-38116 Braunschweig

PhB36-Ex.mdx

Physikalisch-Technische Bundesanstalt
Braunschweig und Berlin

PTB

Test Report **PTB Ex 03-23096**

(13) **Schedule**

(14) **EC TYPE EXAMINATION CERTIFICATE No. PTB 03 ATEX 2047 X**

(15) **Description of Equipment**

The Model 4748-B, Position Indicator serves for monitoring the valve stem position. The valve is actuated by the Hall magnet. The range in position of a permanent magnet dependent on the valve stem position is converted into the standard signal of 4 to 20 mA and fed to the downstream transducer electronics.

For air supply non-combustible media are used.

The correlation between temperature classification and permissible ambient temperature range is shown in the table below.

Temperature class	Permissible ambient temperature range
T6	-45 °C... 60 °C
T5	-45 °C... 70 °C
T4	-45 °C... 80 °C

Electrical data

Signal circuit
Type of protection EEx nA II

(terminals 31/32)

(16) **Test Report PTB Ex 03-23096**

(17) **Special conditions for safe use**

The Model 4748-B, Position Indicator shall be installed in an enclosure providing at least Degree of Protection IP 54 in compliance with the IEC Publication 60529: 1089. This requirement applies also to cable entries and/or plug connectors.

The wiring shall be connected in such a manner that the connection facilities are not subjected to pull and/or twisting.

EC Type Examination Certificates without signature and seal are invalid.
This EC Type Examination Certificate may only be reproduced in its entirety and without any changes, schedule included.
Extracts or changes shall require the prior approval of the Physikalisch-Technische Bundesanstalt.

Physikalisch-Technische Bundesanstalt, Bundesallee 100, D-38116 Braunschweig

PH34-Ex.pdf

Physikalisch-Technische Bundesanstalt
Braunschweig und Berlin

PTB

Test Report **PTB Ex 03-23096**

The signal circuit (terminals 31/32) shall be provided with a series connected fuse outside of the hazardous location. This fuse shall comply with IEC 127/2/II, 250 V F, or with IEC 127-2/VI, 250 V T, with a nominal fuse current of $I_N \leq 63$ mA.

(18) **Special Health and Safety Requirements**

In compliance with the standards specified above.

Zertifizierungsstelle Explosionsschutz
By order

Braunschweig, 2 June 2003

(Signature) (seal)

Dr.-Ing. U. Johannsmeyer
Regierungsdiraktor

EC Type Examination Certificates without signature and seal are invalid.
This EC Type Examination Certificate may only be reproduced in its entirety and without any changes, schedule included.
Extracts or changes shall require the prior approval of the Physikalisch-Technische Bundesanstalt.

Physikalisch-Technische Bundesanstalt, Bundesallee 100, D-38116 Braunschweig

PH34-Ex.pdf



SAMSON AG · MESS- UND REGELTECHNIK
Weismüllerstraße 3 · 60314 Frankfurt am Main · Germany
Phone: +49 69 4009-0 · Fax: +49 69 4009-1507
Internet: <http://www.samson.de>

EB 8363 EN

2008-01